

# Sub Pump Piusi SQUAL Adblue

## FEATURES

- **HEAVY DUTY**
- **REGENERATIVE TURBINE**
- **INTEGRATED PRESSURE REGULATOR**
- **BUILT-IN NON RETURN VALVE**

SQUALO35 is the first submersible pump for AdBlue® to have been especially developed and tested for distribution systems. A centrifugal pump fitted with a turbine regenerator with non-return valve and a built-in innovative pressure regulation system that optimises flow rate performance levels. Consistent flow rate and accuracy during delivery dramatically reduce energy consumption levels. The compact size and special pump design make for easy installation and near-complete emptying of the intended installation tank.

## PERFORMANCE

UP TO  
**35 L/MIN**

FLOW RATE

**AC**  
VOLTAGE

POWER

**30 MM**

DEAD LEVEL



**SQUALO35**

## PACKAGING

CODE	WEIGHT		PACKAGING		
	KG	LBS	MM	INCH	PCS/BOX
FO0206020	7	15,4	510X240X150	20X9,4X5,6	1

**AUSTRALIA**  
+61 3 9775 1366  
FUELCO.COM.AU

**AFRICA**  
+27 (016) 421 8043  
FUELCO-SA.COM

**MENA**  
+ 971 4 232 4985  
FUELCO.AE

# Sub Pump Piusi SQUAL Adblue

## CHART

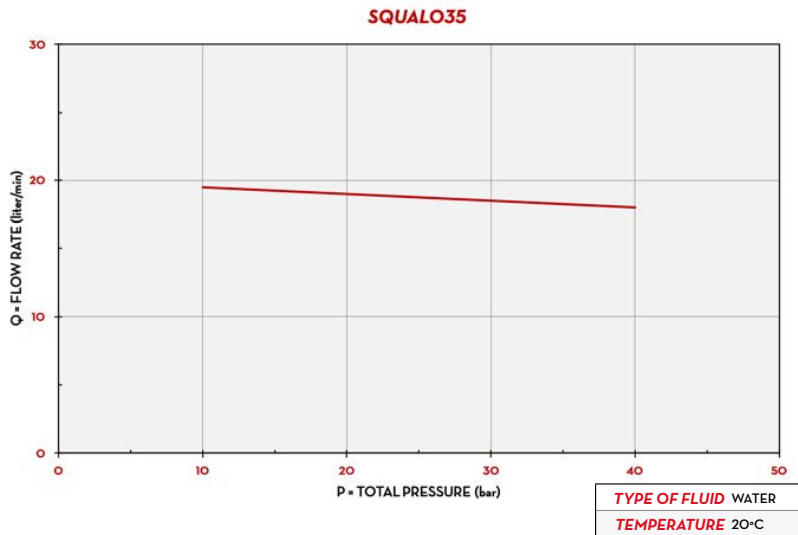

## IN THE BOX

- SQUALO35
- INSTRUCTION MANUAL

## DETAILS



## DIMENSIONS

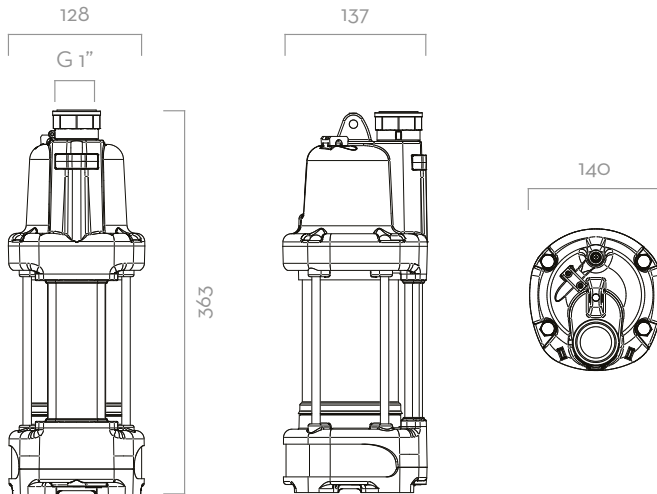

Dimensions expressed in millimeters

## MATERIALS

- BODY: STAINLESS STEEL/TECHNOPOLYMER
- TURBINE: TECHNOPOLYMER

## TECHNICAL DATA

CODICE	DESCRIPTION	FLUIDS TYPE	WORKING PRESSURE	FLOW RATE		VOLTAGE		DEAD LEVEL	POWER CORD
				L/MIN	GPM	CA V/Hz CC V	WATT		
FOO206020	SQUALO35 230/50 TIMER	 W	1,8 BAR 27 PSI	35	7,7	230/50	560	30 MM	5 M

**SQUALO35**

**AUSTRALIA**  
 +61 3 9775 1366  
 FUELCO.COM.AU

**AFRICA**  
 +27 (016) 421 8043  
 FUELCO-SA.COM

**MENA**  
 + 971 4 232 4985  
 FUELCO.AE