

Piusi ST Box Panther 72 Pro

FEATURES

- **STURDY STRUCTURE**
- **LOCKABLE AND SAFE**
- **READY TO USE**
- **FILTRATION GUARANTEED**
- **NOZZLE CONTACT (PRO VERSION ONLY)**

The PIUSI ST BOX is a diesel refueling station complete with pump, flow meter, and filter, with lockable metal protection box. The unit is complete with antistatic hose for diesel fuel and automatic dispensing nozzle. The PRO version features the electronic access control box ACCESS 85.

PERFORMANCE

UP TO
90 L/MIN

FLOW RATE

AC
CONTINUOUS DUTY
POWER

± 1%

ACCURACY

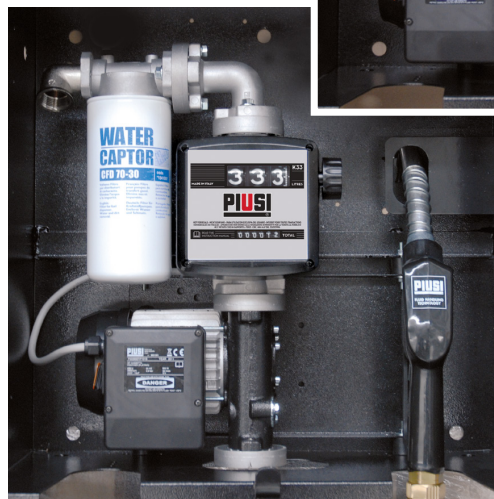

PACKAGING

| CODE | WEIGHT | | PACKAGING | | |
|--------------------------|--------|-----|-------------|----------------|---------|
| | KG | LBS | MM | INCH | PCS/BOX |
| WITHOUT ACCESS 85 | | | | | |
| 00036700B | - | - | - | - | - |
| 00036900B | - | - | - | - | - |
| FO0365020 | - | - | - | - | - |
| FO0365060 | - | - | - | - | - |
| FO0365050 | 36 | 72 | 575X320X607 | 22,6X12,6X23,9 | 1 |
| FO03650A | 40 | 88 | 575X320X607 | 22,6X12,6X23,9 | 1 |
| FO039900A | 50 | 110 | 590X340X720 | 23,2X13,4X28,3 | 1 |
| WITH ACCESS 85 | | | | | |
| FO0365010 | 40 | 88 | 575X320X607 | 22,6X12,6X23,9 | 1 |

AUSTRALIA
+61 3 9775 1366
FUELCO.COM.AU

AFRICA
+27 (016) 421 8043
FUELCO-SA.COM

MENA
+ 971 4 232 4985
FUELCO.AE

Piusi ST Box Panther 72 Pro

CHART

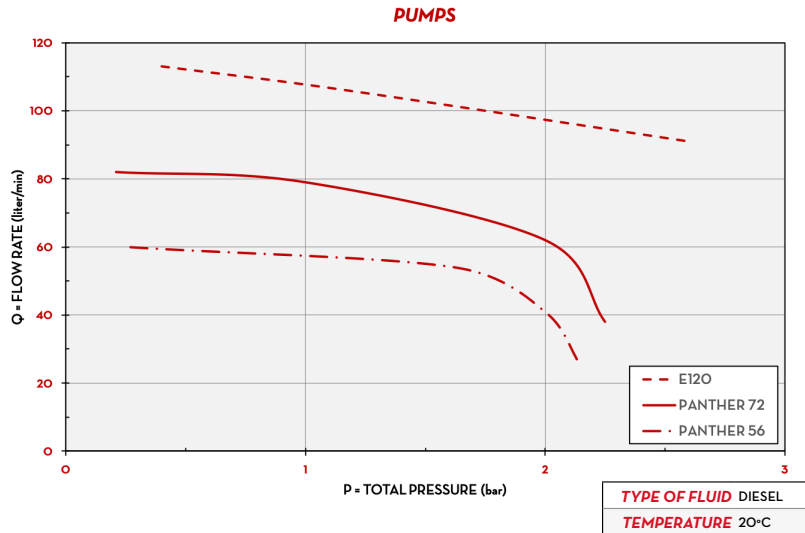

DIMENSIONS

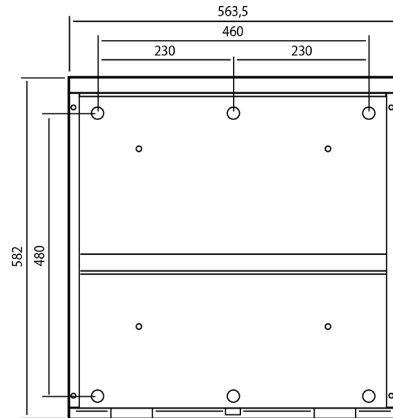

Dimensions expressed in millimeters

IN THE BOX

- ST BOX UNIT
- METER
- FILTER
- DELIVERY HOSE
- NOZZLE
- INSTRUCTION MANUAL

DETAILS

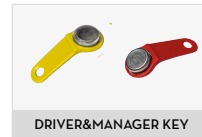

COMPONENTS

- **PUMPS:**
 PANTHER AC PAG. 102
 E80/E120 PAG. 106
 BIPUMP PAG. 116
- **NOZZLE:**
 AUTOMATIC NOZZLE PAG. 158
- **METER:**
 K33 PAG. 146
 K24 PAG. 132
- **FILTER**
 WATER CAPTOR PAG. 170
- **ACCESS CONTROL**
 ACCESS85 PAG. 194

TECHNICAL DATA

| CODE | DESCRIPTION | FLUIDS TYPE | FLOW RATE | | VOLTAGE | | | PUMP TYPE | METER TYPE | NOZZLE TYPE | FILTER H2O FILTER | HOSE | | INLET BSP |
|--------------------------|----------------------------|-------------|-----------|-----|----------|---------|------------|-----------|------------|-------------|-------------------|-----------|--------|-----------|
| | | | L/MIN | GPM | AC V/ HZ | DC VOLT | POWER WATT | | | | | AMP. MAX. | LENGTH | |
| WITHOUT ACCESS 85 | | | | | | | | | | | | | | |
| 00036700B | ST BOX E80/M K33 A80 | D | 80 | 21 | 230/50 | 500 | 3,5 | E80 | K33 | A80 | NO | 4M | 1" | 1" |
| 00036900B | ST BOX E120/M K33 A120 | D | 90 | 22 | 230/50 | 750 | 5,7 | E120 | K33 | A120 | NO | 4M | 1" | 1" |
| FO0365020 | ST BOX PANTHER 56 BASIC | D | 56 | 15 | 230/50 | 350 | 3 | PANTH. 56 | K33 | A60 | YES | 6M | 1" | 1" |
| FO0365060 | ST BOX PANTHER 72 BASIC | D | 70 | 19 | 230/50 | 500 | 4,2 | PANTH. 72 | K33 | A80 | YES | 6M | 1" | 1" |
| FO0365050 | ST BOX E 120 BASIC | D | 90 | 22 | 230/50 | 750 | 5,7 | E 120 | K33 | A120 | YES | 8M | 1" | 1" |
| FO0365POA | ST BOX P56/M K33 A60 | D | 56 | 15 | 230/50 | 350 | 3 | PANTH. 56 | K33 | A60 | NO | 4M | 3/4" | 1" |
| FO039900A | ST BOX BIPUMP 12V K33 A120 | D | 80 | 21 | 12 | 530 | 44 | BIPUMP | K33 | A80 | NO | 4M | 1" | 1" |
| WITH ACCESS 85 | | | | | | | | | | | | | | |
| FO0365010 | ST BOX PANTHER 72 PRO | D | 70 | 19 | 230/50 | 500 | 4,2 | PANTH. 72 | K33 | A60 | YES | 8M | 1" | 1" |

PRO VERSION ONLY

ST BOX

AUSTRALIA
 +61 3 9775 1366
 FUELCO.COM.AU

AFRICA
 +27 (016) 421 8043
 FUELCO-SA.COM

MENA
 + 971 4 232 4985
 FUELCO.AE