

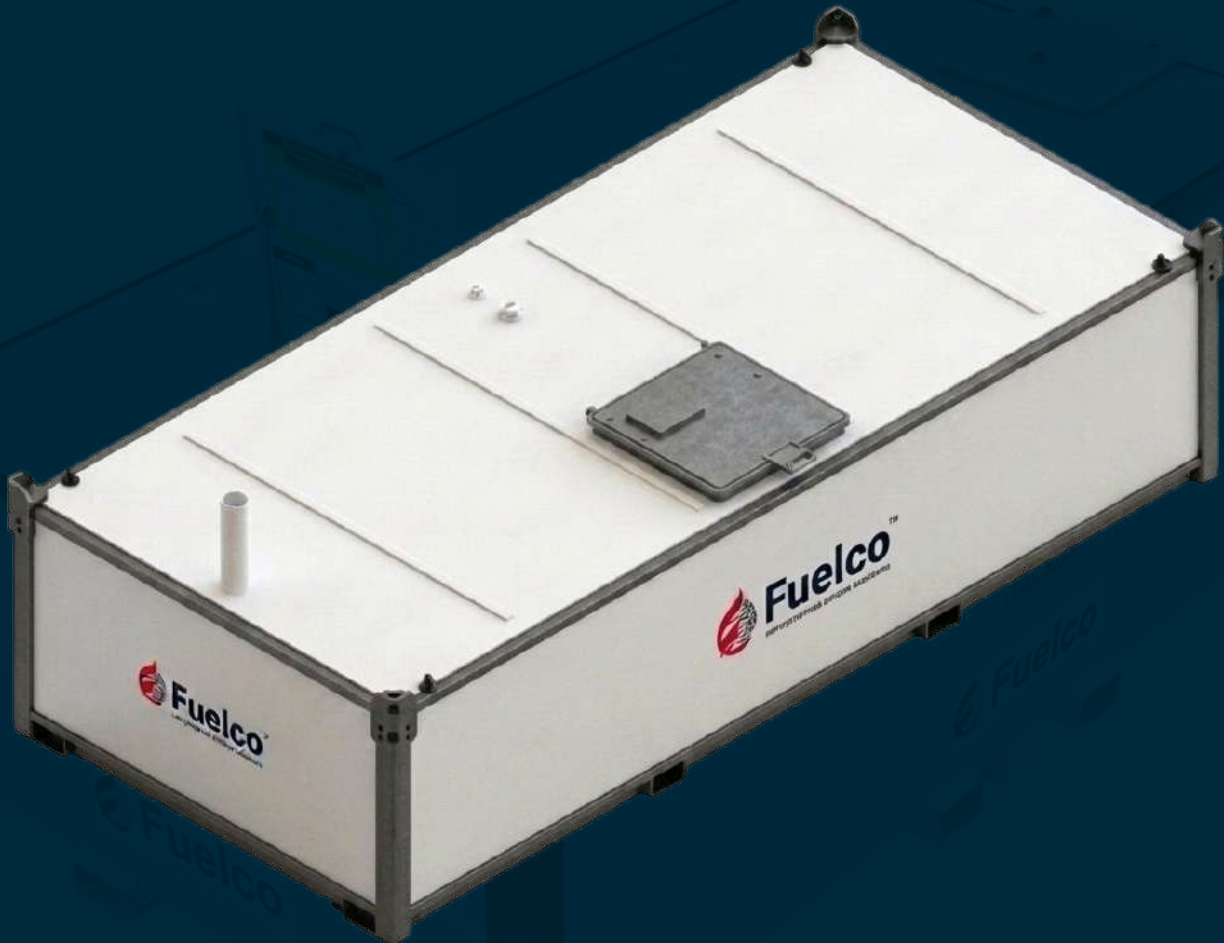

Fuelco™

complete fuel storage solutions



SPEC SHEET

**Kube Self Bunded Tank
PC 11000L**

Kube PC 11000L Self Bunded Tank

Standard Tanks Features:

- **LOCKABLE CONTAINMENT** - For securely housing pumps and hose connections
- **LIFTING POINTS** - Simplifying crane handling
- **SECURE MANWAY** - Providing access to tank for cleaning and inspections
- **GALVANISED EDGE**- Prevents nicks and damages
- **BAFFLED INTERNALLY** - Restricts movement of product
- **DECALS** - Providing clear critical information to operators or users
- **DIKED DESIGN** - Allowing the inner tank to be removed from the outer tank
- **CORNER POSTS** - Providing full edge protection
- **FORK POCKETS** - Double sided to provide access from all sides



Specification	Details
Tank Model	PC 11
Gross Fill	11000 litres
Safe Fill	10350 litres
Length	4,876 mm
Width	2,294 mm
Height	1,270 mm
Tare Weight	2757 kg
Compliance	UL142, ULC S601, AS1940, AS1692, BS799-5

Disclaimer: Information and photographs shown are for marketing purposes only. Actual product may vary to images shown due to continual improvement processes, design changes and optional extras.

Contact details:

- ☎ +61 (03) 9775 1366
- ✉ sales@fuelco.com.au
- 🌐 fuelco.com.au

Request a Quote Today

Fuelco holds stock of these tanks in ALL states across Australia. For details on availability and pricing, please contact your local state manager.



DO NOT SCALE FROM DRAWING. IF IN DOUBT: ASK

UNLESS OTHERWISE SPECIFIED, ALL DIMENSIONS ARE IN MILLIMETRES

Tank	
TANK CONTENTS	
DESIGNED TO	AS1940 / AS1692
BUILT TO	AS1657 / AS1554.1
PLATE THICKNESS, Material	4/4 mm, Q235B
Pressue Test	21KPA
External size	4876x2294x1270mm
Internal size	4768x2186x1058mm
GROSS VOLUME	11000L
SAFE FILL LEVEL	10350L
N. D. T.	Require By Client
TOTAL MASS	2757.94KG

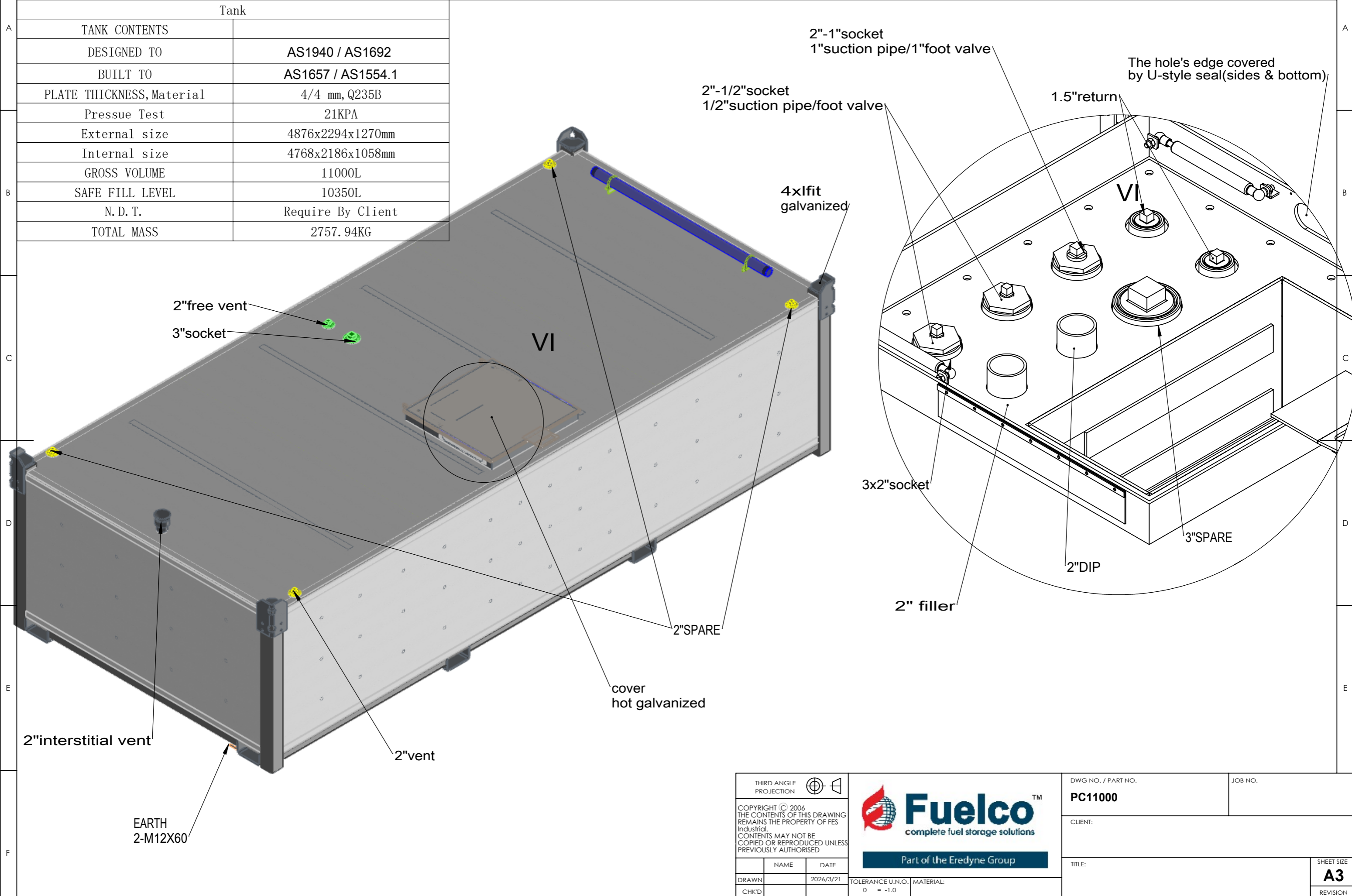

THIRD ANGLE PROJECTION	
COPYRIGHT © 2006 THE CONTENTS OF THIS DRAWING REMAINS THE PROPERTY OF FES Industrial. CONTENTS MAY NOT BE COPIED OR REPRODUCED UNLESS PREVIOUSLY AUTHORISED	
NAME	DATE
DRAWN	2026/3/21
CHK'D	
APP'V'D	



Fuelco™

 complete fuel storage solutions

 Part of the Eredyne Group

DWG NO. / PART NO.	PC11000	JOB NO.	
CLIENT:			
TITLE:			
SCALE: N.T.S.	SHEET 1 OF 4	SHEET SIZE	A3
		REVISION	01

DO NOT SCALE FROM DRAWING. IF IN DOUBT: ASK

UNLESS OTHERWISE SPECIFIED, ALL DIMENSIONS ARE IN MILLIMETRES

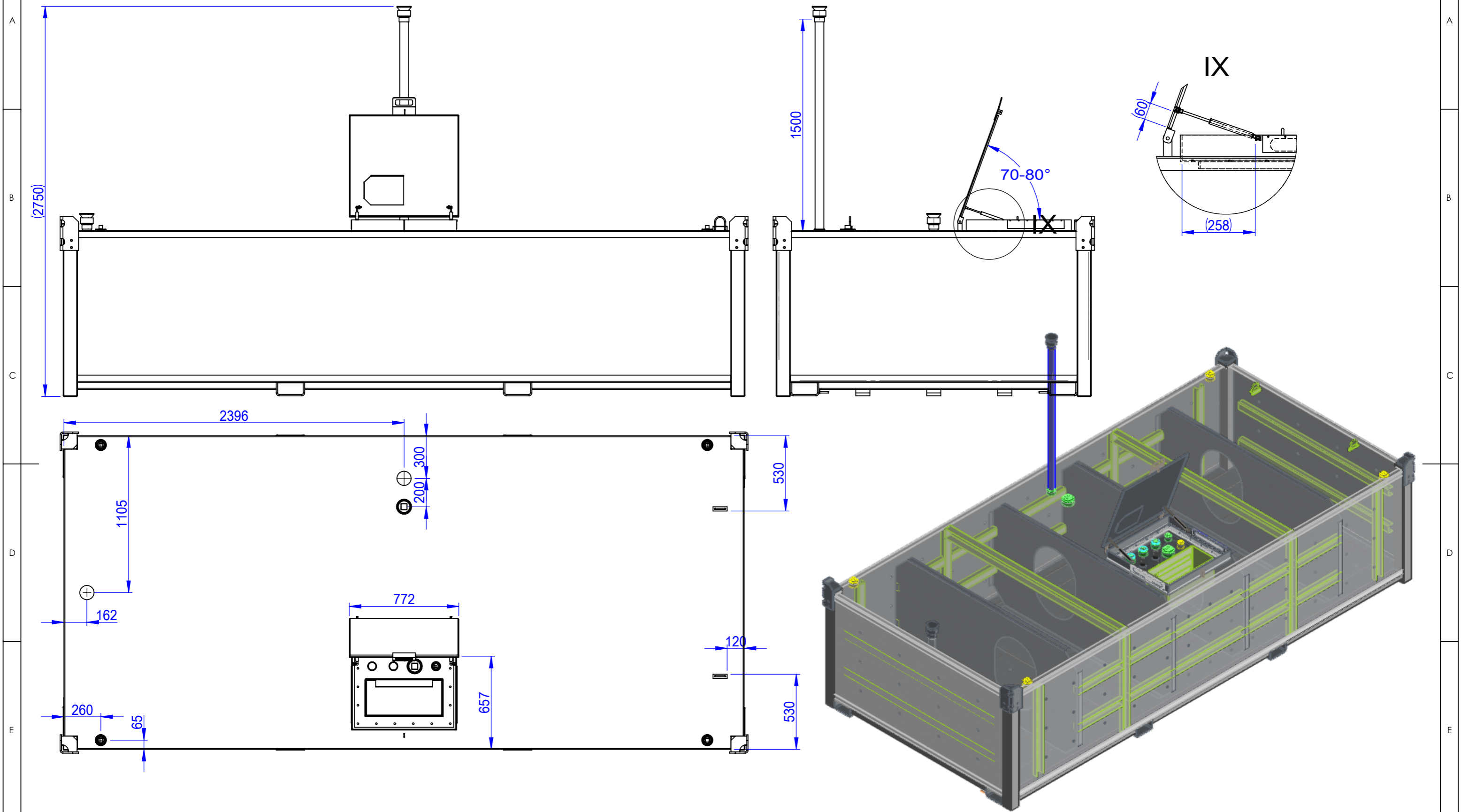

THIRD ANGLE PROJECTION

COPYRIGHT © 2006
THE CONTENTS OF THIS DRAWING
REMAINS THE PROPERTY OF FES
Industrial.
CONTENTS MAY NOT BE
COPIED OR REPRODUCED UNLESS
PREVIOUSLY AUTHORIZED

	NAME	DATE
DRAWN		2026/3/21
CHK'D		
APPV'D		

Fuelco™
complete fuel storage solutions

Part of the Eredyne Group

TOLERANCE U.N.O. MATERIAL:
0 = -1.0
0.0 = -0.4
0.00 = -0.1
WEIGHT: 2757.94 Kg

DWG NO. / PART NO. PC11000		JOB NO.
CLIENT:		
TITLE:		SHEET SIZE A3
SCALE: N.T.S.	SHEET 2 OF 4	REVISION 01

DO NOT SCALE FROM DRAWING. IF IN DOUBT: ASK

UNLESS OTHERWISE SPECIFIED, ALL DIMENSIONS ARE IN MILLIMETRES

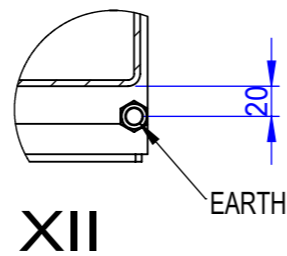
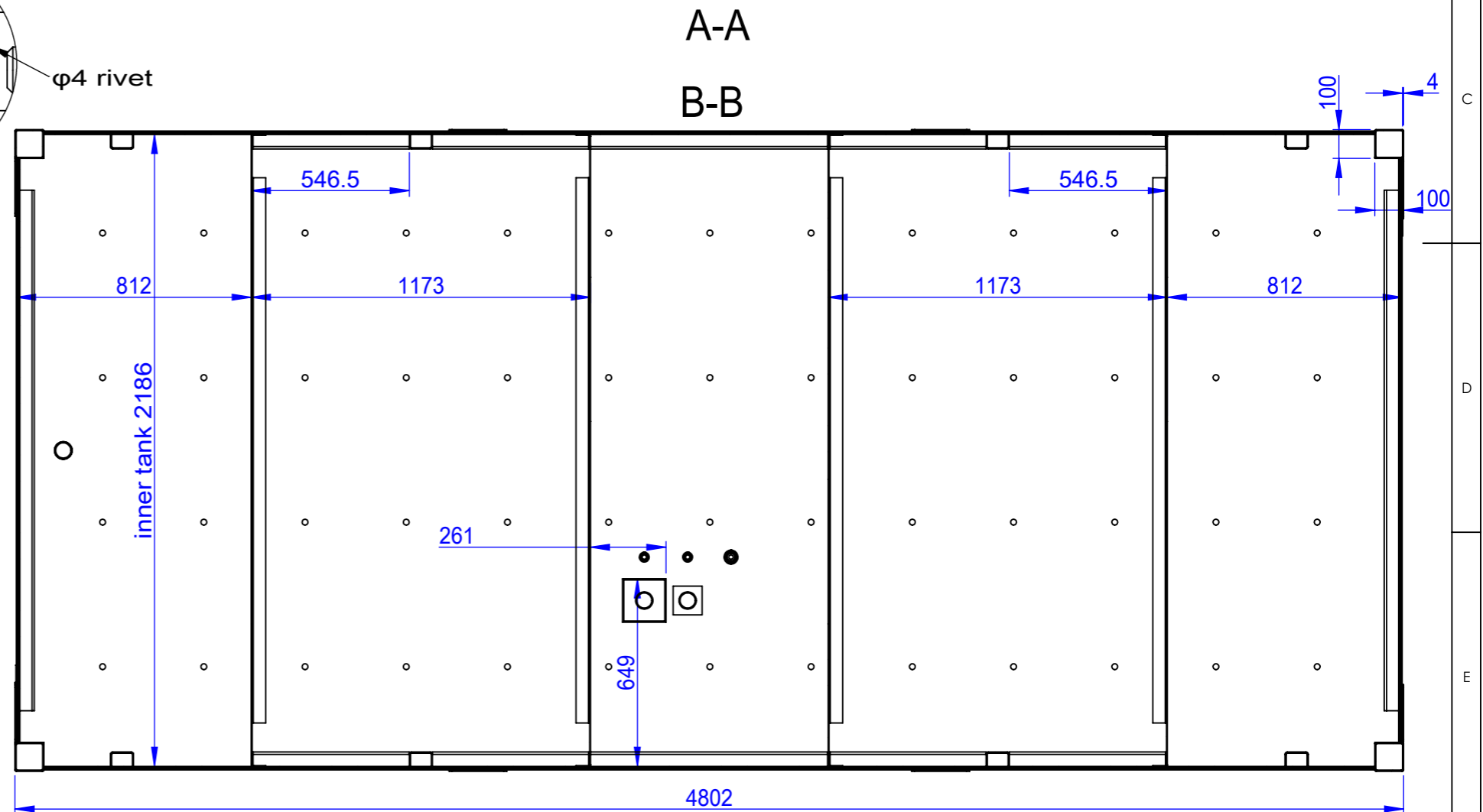
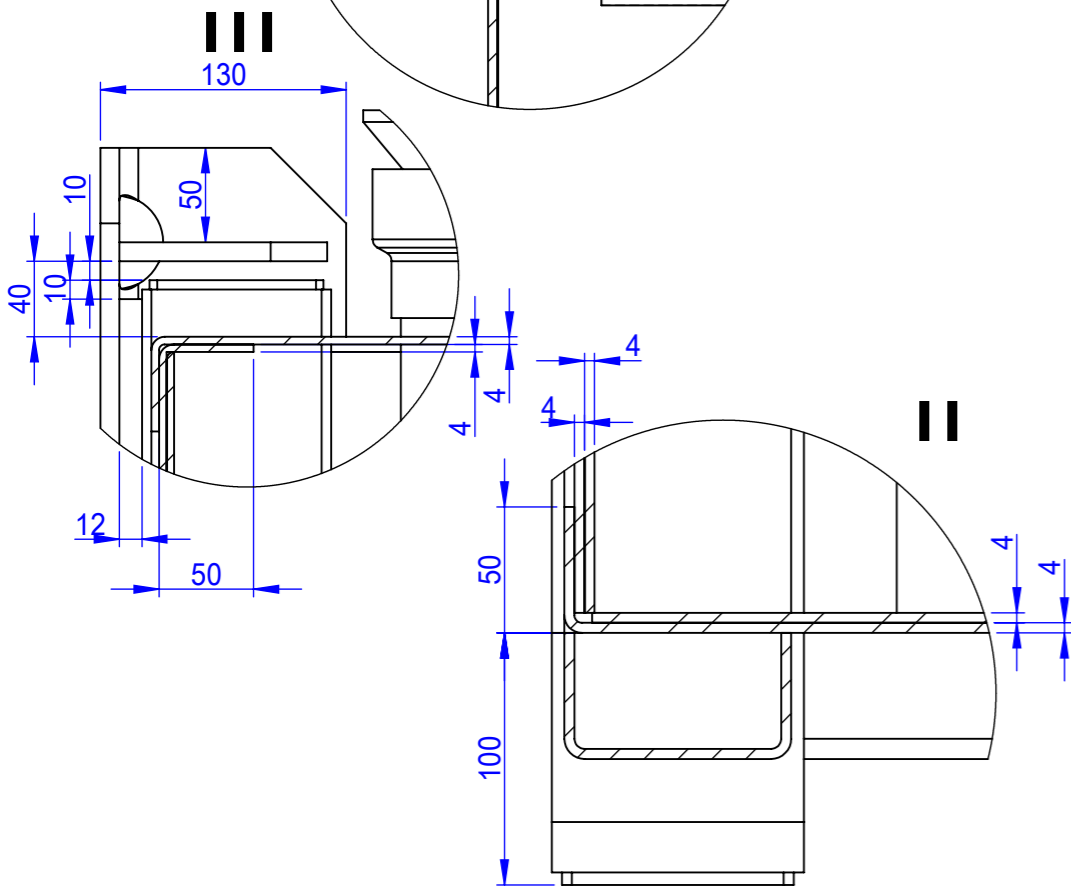
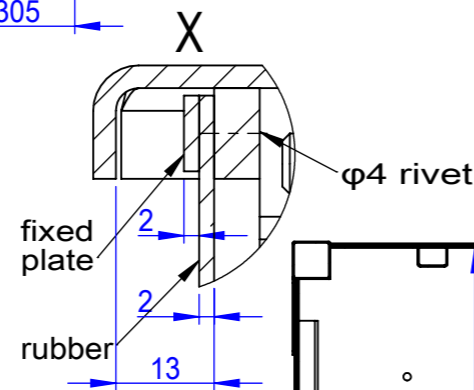
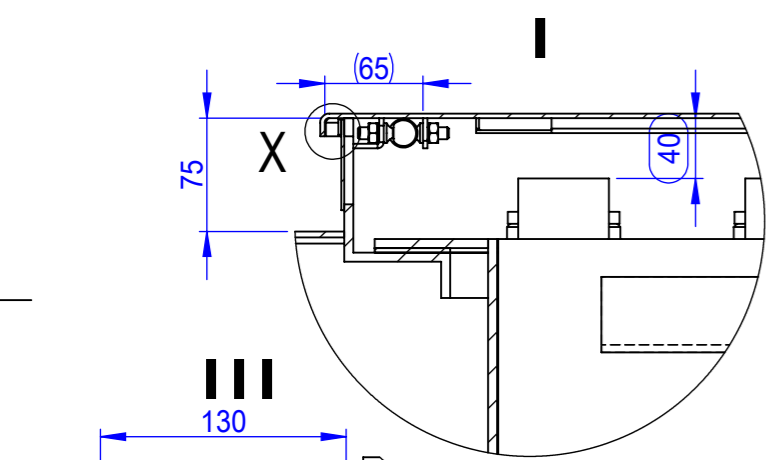
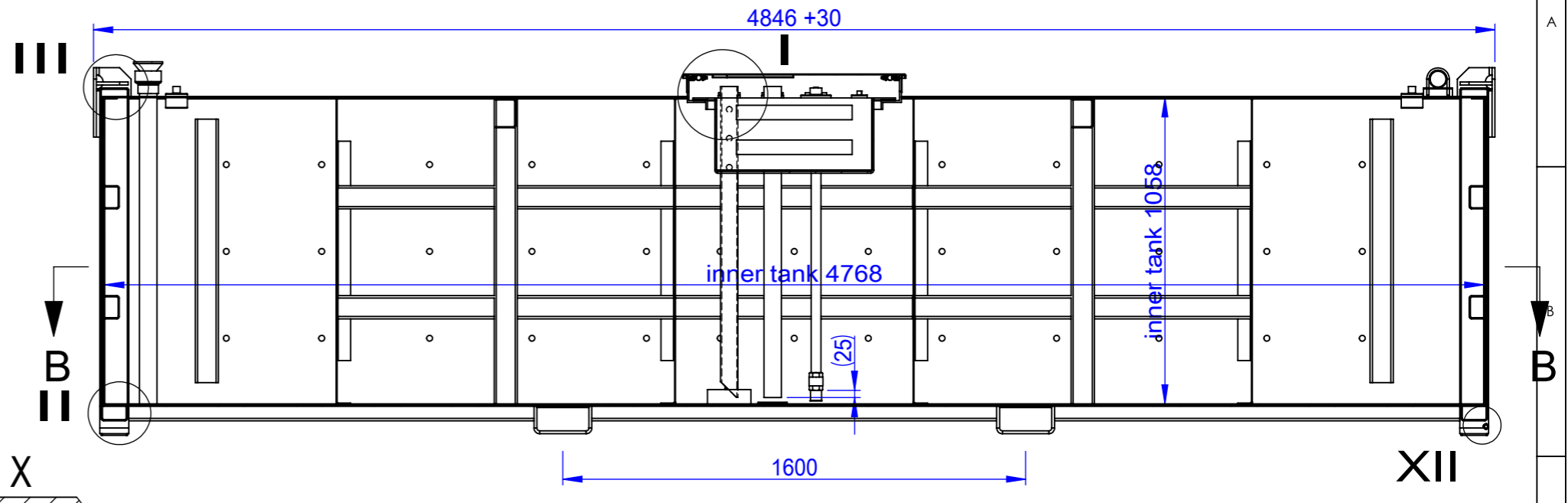
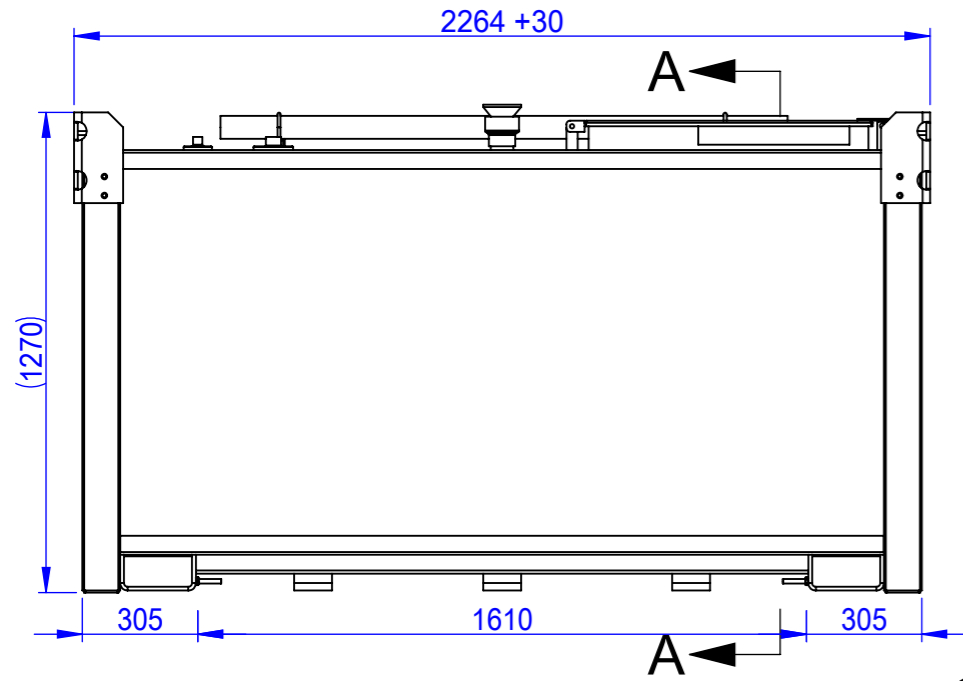

THIRD ANGLE PROJECTION	
COPYRIGHT © 2006 THE CONTENTS OF THIS DRAWING REMAINS THE PROPERTY OF FES Industrial. CONTENTS MAY NOT BE COPIED OR REPRODUCED UNLESS PREVIOUSLY AUTHORISED	
NAME	DATE
DRAWN	2026/3/21
CHK'D	
APP'V'D	

Fuelco™
complete fuel storage solutions

Part of the Eredyne Group

TOLERANCE U.N.O.
0 = -1.0
0.0 = -0.4
0.00 = -0.1

MATERIAL:
WEIGHT: 2757.94 Kg

DWG NO. / PART NO. PC11000	JOB NO.
CLIENT:	
TITLE:	
SCALE: N.T.S.	SHEET 3 OF 4
SHEET SIZE A3	REVISION 01

DO NOT SCALE FROM DRAWING. IF IN DOUBT: ASK

UNLESS OTHERWISE SPECIFIED, ALL DIMENSIONS ARE IN MILLIMETRES

1 : 20

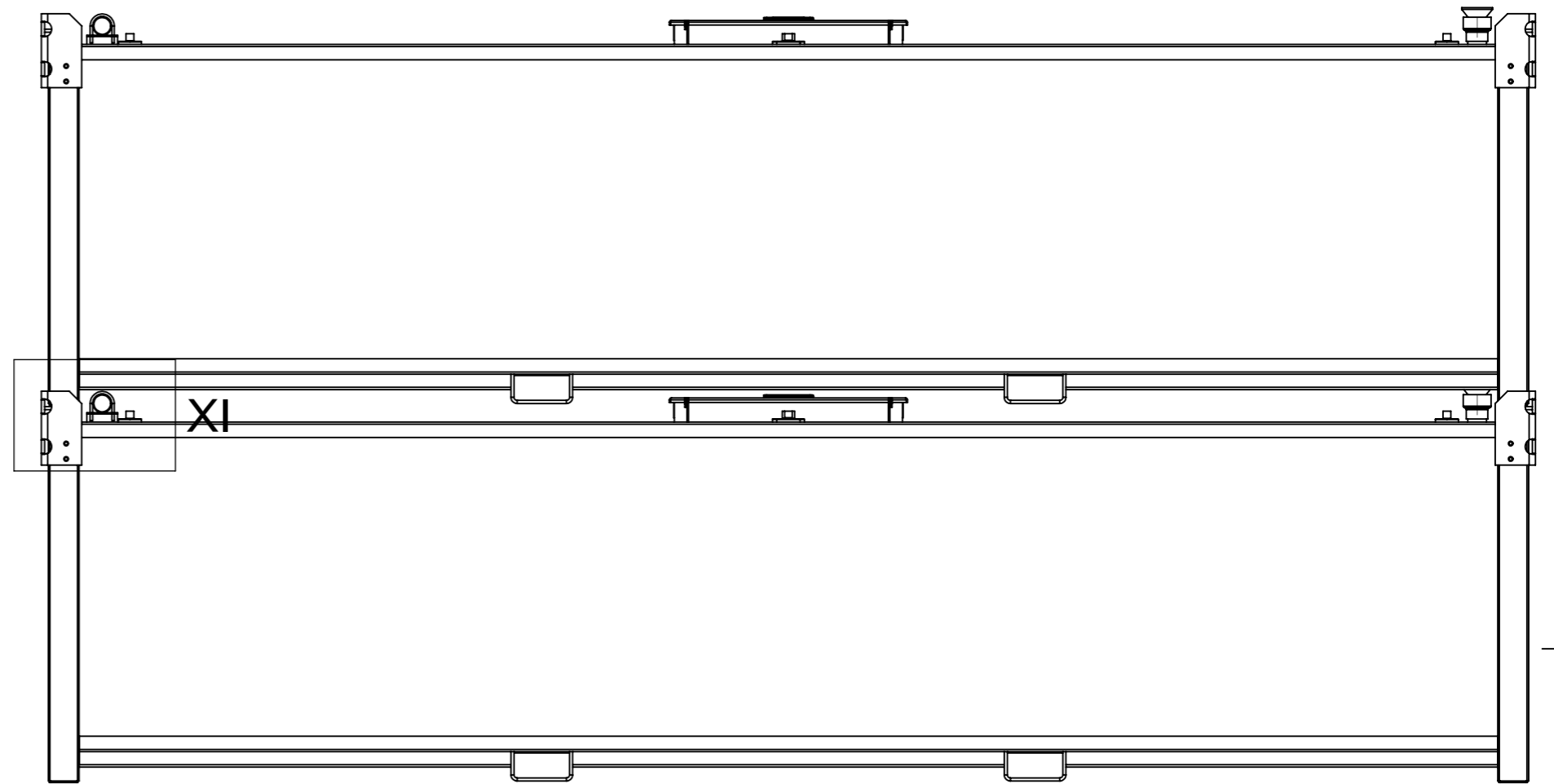
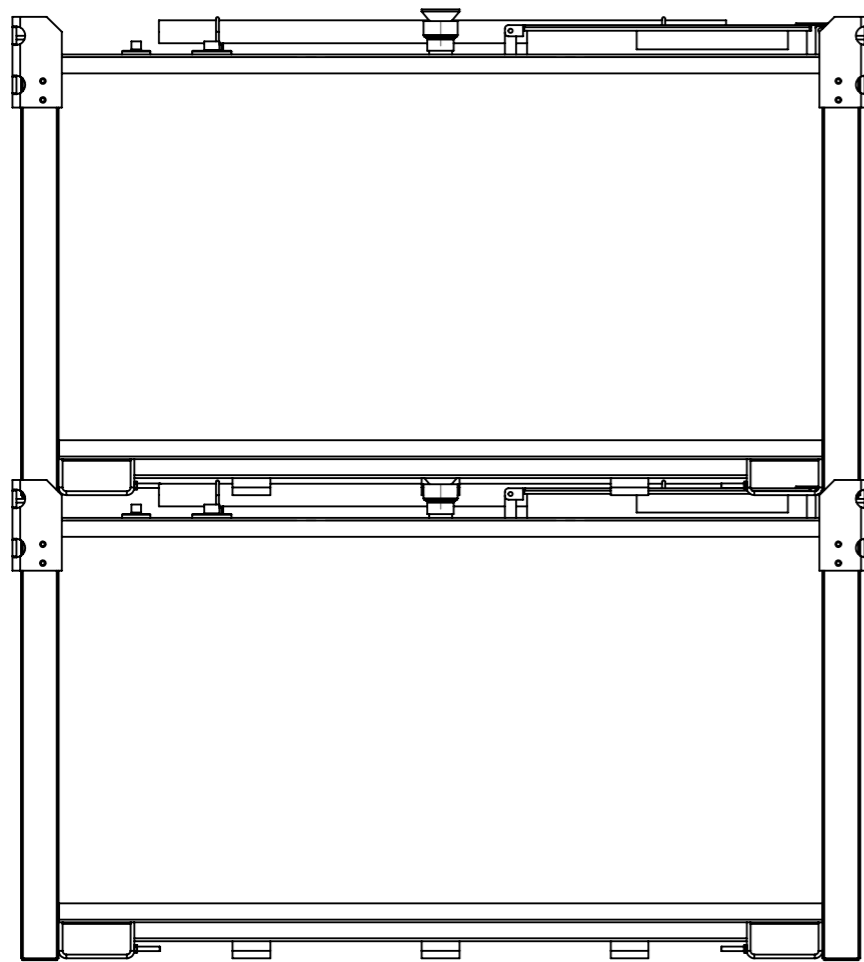

XI

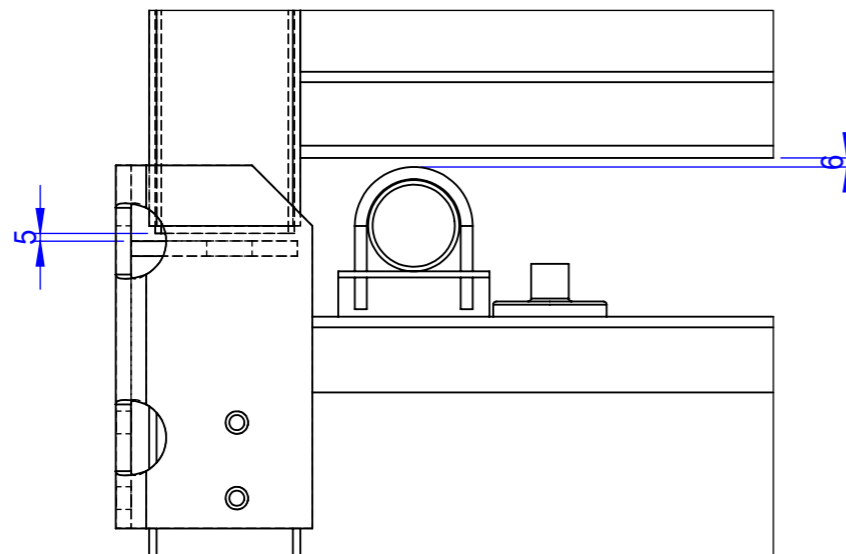

THIRD ANGLE PROJECTION			
COPYRIGHT © 2006 THE CONTENTS OF THIS DRAWING REMAINS THE PROPERTY OF FES Industrial. CONTENTS MAY NOT BE COPIED OR REPRODUCED UNLESS PREVIOUSLY AUTHORISED			
	NAME	DATE	
DRAWN		2026/3/21	
CHK'D			
APPV'D			



Part of the Eredyne Group

TOLERANCE U.N.O. MATERIAL:
 0 = -1.0
 0.0 = -0.4
 0.00 = -0.1
 WEIGHT: 5514.145 Kg

DWG NO. / PART NO.		JOB NO.	
叠箱			
CLIENT:			
TITLE:			SHEET SIZE
SCALE: N.T.S.			A3
SHEET 4 OF 4			REVISION