



Fuelco™

complete fuel storage solutions



SPEC SHEET

**Kube Self Bunded Tank
2,000L**

Kube 2000L Self Bunded Tank

Standard Tanks Features:



- **LOCKABLE CONTAINMENT** - For securely housing pumps and hose connections
- **LIFTING POINTS** - Simplifying crane handling
- **SECURE MANWAY** - Providing access to tank for cleaning and inspections
- **GALVANISED EDGE**- Prevents nicks and damages
- **BAFFLED INTERNALLY** - Restricts movement of product
- **DECALS** - Providing clear critical information to operators or users
- **DIKED DESIGN** - Allowing the inner tank to be removed from the outer tank
- **CORNER POSTS** - Providing full edge protection
- **FORK POCKETS** -Double sided to provide access from all sides



Specification	Details
Tank Model	LTKD2
Gross Fill	2063 litres, (545 USG / 453 IG)
Safe Fill	1960 litres, (518 USG / 431 IG)
Length	2230 mm, (87.79 in)
Width	1130 mm, (44.48 in)
Height	1274 mm, (50.15 in)
Tare Weight	750 kg,
Compliance	UL142, ULC S601, AS1940, AS1692, BS799-5, UN31A

Disclaimer: Information and photographs shown are for marketing purposes only. Actual product may vary to images shown due to continual improvement processes, design changes and optional extras.

Contact details:

 +61 (03) 9775 1366
 sales@fuelco.com.au
 fuelco.com.au

Request a Quote Today

Fuelco holds stock of these tanks in ALL states across Australia. For details on availability and pricing, please contact your local state manager.



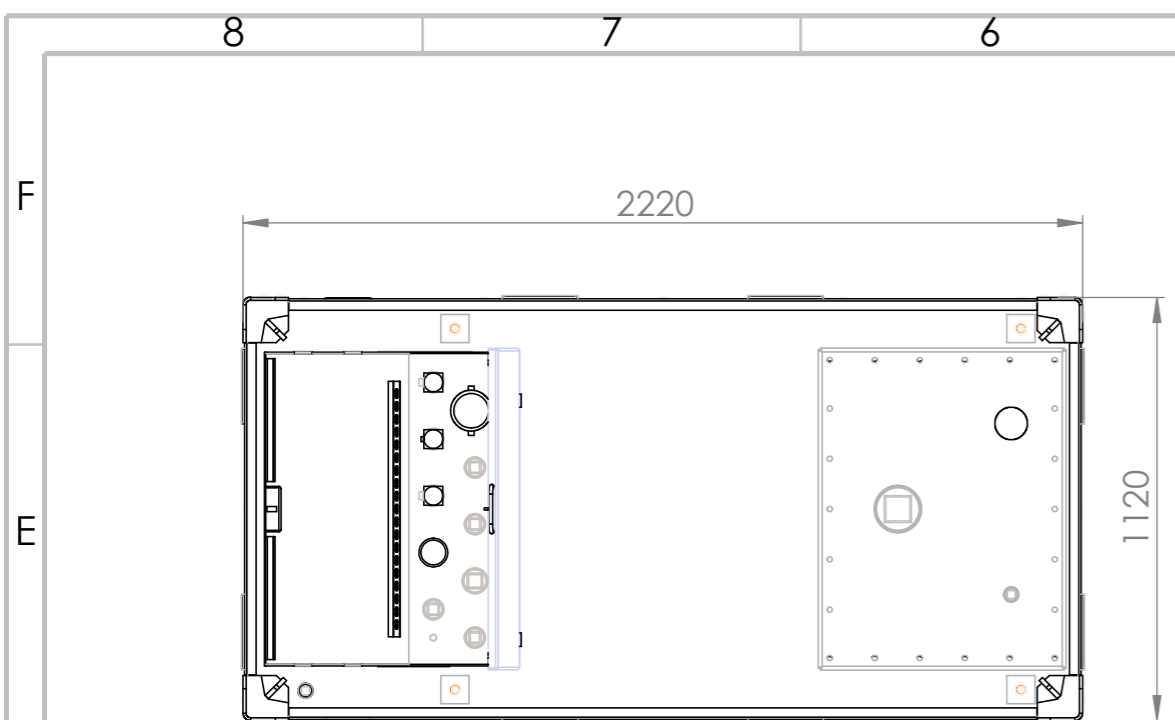

- NOTES:
1. BAFFLED INTERNALLY.
 2. CONTAINMENT AREA FOR PUMP, HOSE AND/OR NOZZLE STORAGE.
 3. DESIGNED TO BE STACKED FOR STORAGE.
 4. VENT PIPE FOR TANKS USED IN AUSTRALIA/NZ.
 5. REAR HATCH WITH SOCKETS FOR AUSTRALIA/NZ.

TANK DATA	
DESIGNED TO BUILT TO	AS1692, UL 142, UN31A
GROSS VOLUME	2 063 L (545 USG / 453 IG)
SAFE FILL LEVEL	1 960 L (518 USG / 431 IG)
PNEUMATIC TEST TOTAL MASS	21-35 kPa (INNER & OUTER) 750 kg (EMPTY)
PAINT	Base Coat: Intergard 345 AkzoNobel (Int.), thickness: 80-100µm
	Top Coat: Interthane 990 AkzoNobel (Int.), thickness: 70-80µm

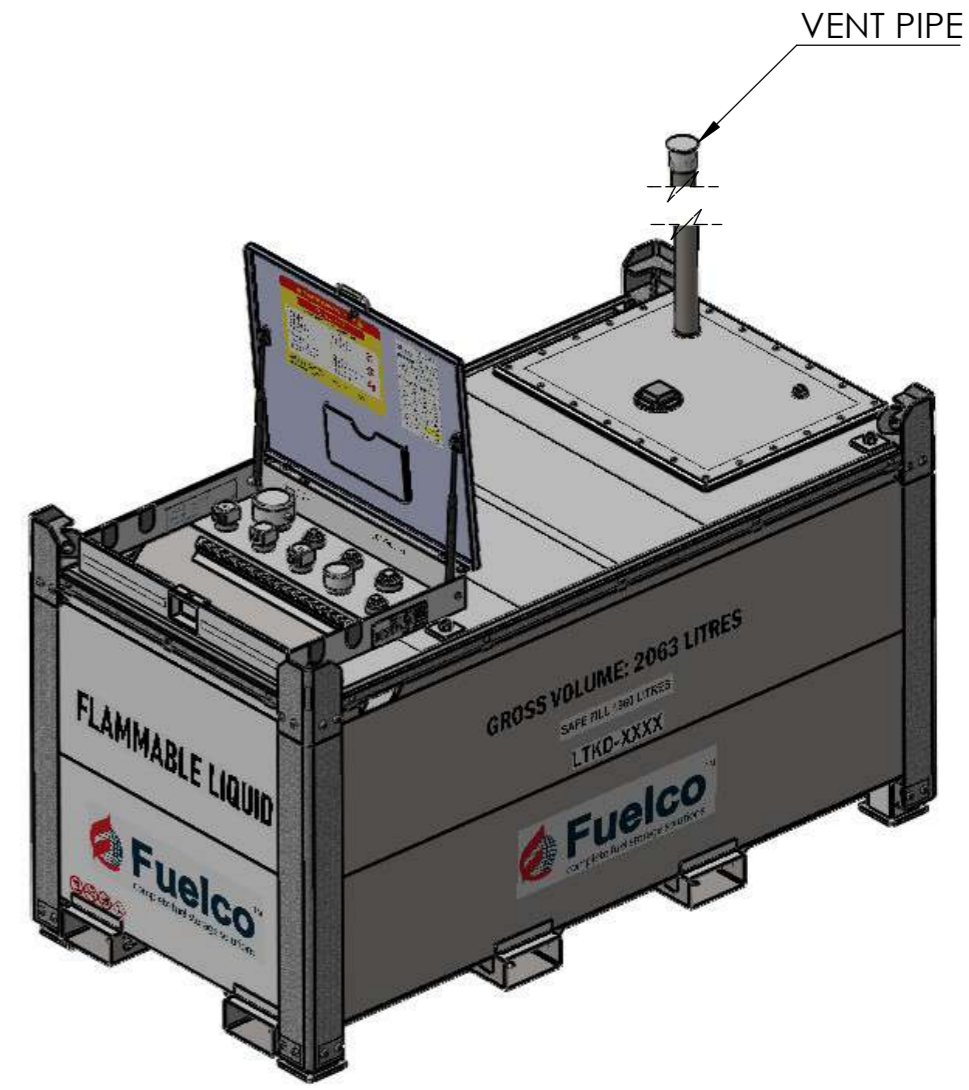
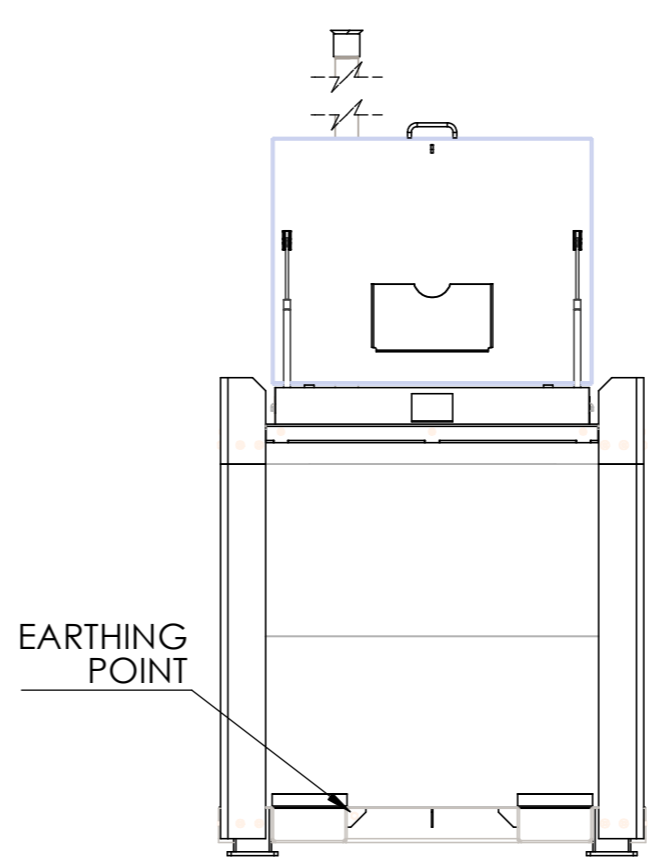
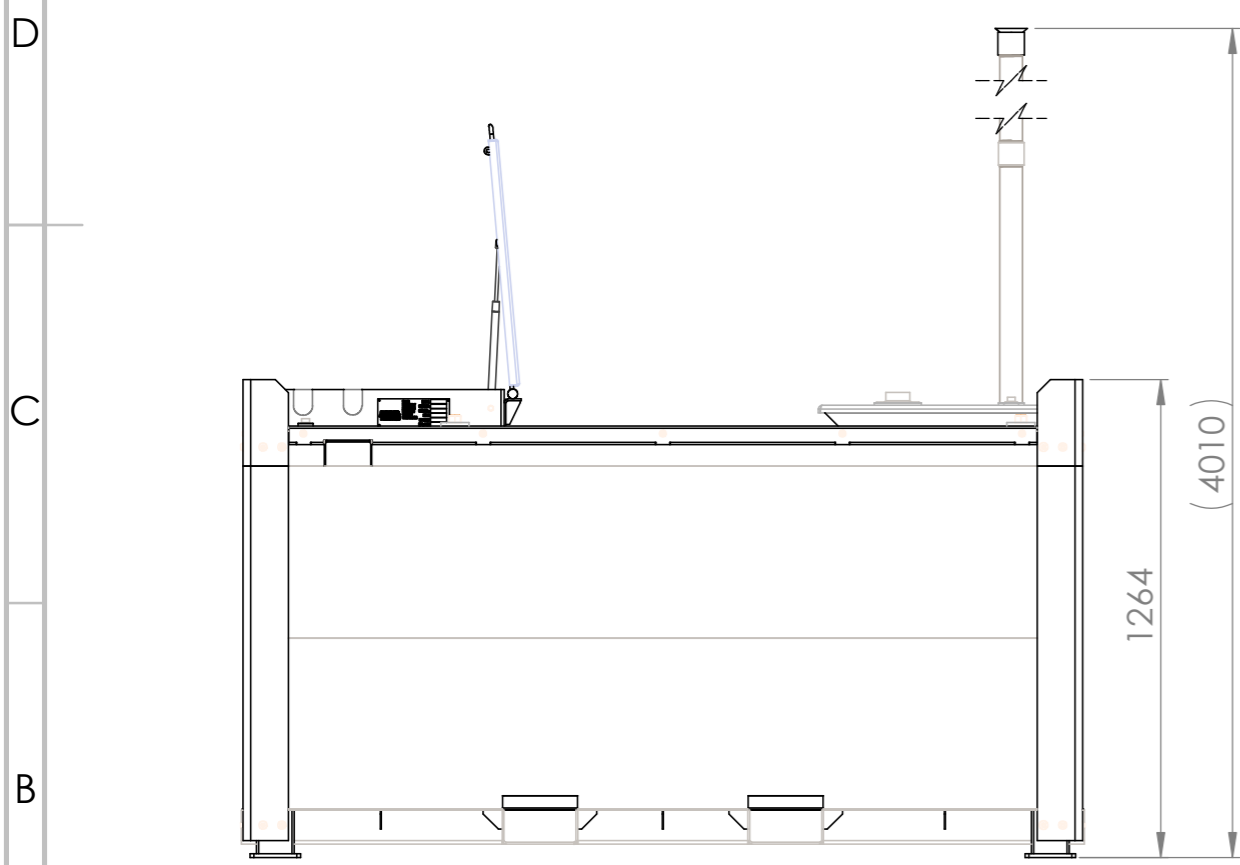

REV.	DESCRIPTION	DATE	DWN	APP
7	RE-ISSUED FOR INFORMATION	23/10/2024	LIB	HS
6	UPDATE FORKLIFT & GUSSET THICKNESS TO 5mm	20/12/2023	RVD	HS
5	UPDATE NOZZLE TABLE	24/02/2023	LIB	HS
4	CHANGED OVERALL HEIGHT TO 1264mm	11/11/2022	LIB	HS
3	RE-ISSUED FOR INFORMATION	06/11/2022	LIB	HS
2	RE-ISSUED FOR INFORMATION	20/09/2022	LIB	HS
1	ISSUED FOR INFORMATION	16/06/2022	LIB	HS
REVISIONS				

IF IN DOUBT ASK. DRAWING INFORMATION TAKES PRECEDENCE OVER PARTS LIST

<p><small>COPYRIGHT. This drawing and the information herein is the property of Fuelco PTY LTD and must not be reproduced, transmitted or disclosed to other parties without written permission from the owners.</small></p>	<p>GENERAL NOTES DO NOT SCALE UNLESS STATED OTHERWISE:- ALL DIMENSIONS IN MILLIMETERS ALL THREADS ARE METRIC COARSE DEBURR & REMOVE ALL SHARP EDGES TOLERANCES:</p> <table border="1"> <thead> <tr> <th>TYPE</th> <th>TOLERANCE</th> </tr> </thead> <tbody> <tr> <td>GENERAL</td> <td>±5.0</td> </tr> <tr> <td>ONE DECIMAL PLACE</td> <td>±0.1</td> </tr> <tr> <td>TWO DECIMAL PLACE</td> <td>±0.1</td> </tr> <tr> <td>ANGULAR (°)</td> <td>±1.0</td> </tr> </tbody> </table>	TYPE	TOLERANCE	GENERAL	±5.0	ONE DECIMAL PLACE	±0.1	TWO DECIMAL PLACE	±0.1	ANGULAR (°)	±1.0	SCALE	NTS	TITLE	<p>LTKD2 ASSEMBLY GENERAL ARRANGEMENT</p> <p>SHEET 1 OF 3</p> <p>DRAWING NUMBER LTKD2-GA</p> <p>REV 7</p>
		TYPE	TOLERANCE												
		GENERAL	±5.0												
		ONE DECIMAL PLACE	±0.1												
TWO DECIMAL PLACE	±0.1														
ANGULAR (°)	±1.0														
DWN	H SINGH	20/01/2022													
MATERIAL															
THICKNESS															
FINISH															

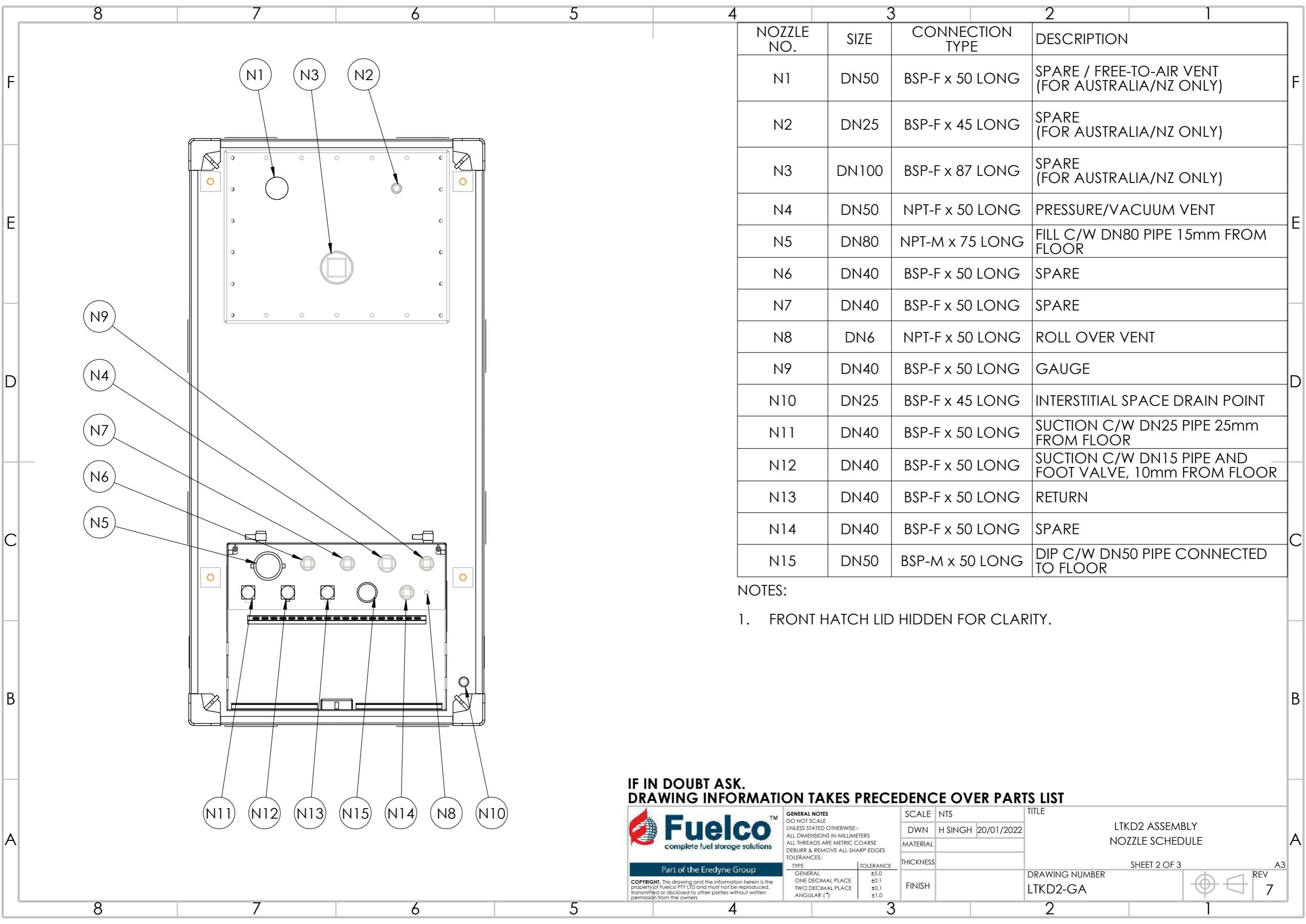

NOZZLE NO.	SIZE	CONNECTION TYPE	DESCRIPTION
N1	DN50	BSP-F x 50 LONG	SPARE / FREE-TO-AIR VENT (FOR AUSTRALIA/NZ ONLY)
N2	DN25	BSP-F x 45 LONG	SPARE (FOR AUSTRALIA/NZ ONLY)
N3	DN100	BSP-F x 87 LONG	SPARE (FOR AUSTRALIA/NZ ONLY)
N4	DN50	NPT-F x 50 LONG	PRESSURE/VACUUM VENT
N5	DN80	NPT-M x 75 LONG	FILL C/W DN80 PIPE 15mm FROM FLOOR
N6	DN40	BSP-F x 50 LONG	SPARE
N7	DN40	BSP-F x 50 LONG	SPARE
N8	DN6	NPT-F x 50 LONG	ROLL OVER VENT
N9	DN40	BSP-F x 50 LONG	GAUGE
N10	DN25	BSP-F x 45 LONG	INTERSTITIAL SPACE DRAIN POINT
N11	DN40	BSP-F x 50 LONG	SUCTION C/W DN25 PIPE 25mm FROM FLOOR
N12	DN40	BSP-F x 50 LONG	SUCTION C/W DN15 PIPE AND FOOT VALVE, 10mm FROM FLOOR
N13	DN40	BSP-F x 50 LONG	RETURN
N14	DN40	BSP-F x 50 LONG	SPARE
N15	DN50	BSP-M x 50 LONG	DIP C/W DN50 PIPE CONNECTED TO FLOOR

NOTES:
 1. FRONT HATCH LID HIDDEN FOR CLARITY.

**IF IN DOUBT ASK.
 DRAWING INFORMATION TAKES PRECEDENCE OVER PARTS LIST**

 <p>FuelcoTM complete fuel storage solutions</p> <p>Part of the Eredyne Group</p> <p><small>COPYRIGHT. This drawing and the information herein is the property of Fuelco PTY LTD and must not be reproduced, transmitted or disclosed to other parties without written permission from the owners</small></p>	<p>GENERAL NOTES DO NOT SCALE UNLESS STATED OTHERWISE:- ALL DIMENSIONS IN MILLIMETERS ALL THREADS ARE METRIC COARSE DEBURR & REMOVE ALL SHARP EDGES TOLERANCES:</p> <table border="1"> <thead> <tr> <th>TYPE</th> <th>TOLERANCE</th> </tr> </thead> <tbody> <tr> <td>GENERAL</td> <td>±5.0</td> </tr> <tr> <td>ONE DECIMAL PLACE</td> <td>±0.1</td> </tr> <tr> <td>TWO DECIMAL PLACE</td> <td>±0.1</td> </tr> <tr> <td>ANGULAR (°)</td> <td>±1.0</td> </tr> </tbody> </table>	TYPE	TOLERANCE	GENERAL	±5.0	ONE DECIMAL PLACE	±0.1	TWO DECIMAL PLACE	±0.1	ANGULAR (°)	±1.0	SCALE	NTS		TITLE	<p>LTKD2 ASSEMBLY NOZZLE SCHEDULE</p> <p>SHEET 2 OF 3</p> <p>DRAWING NUMBER LTKD2-GA</p>	<p>REV 7</p>
		TYPE	TOLERANCE														
		GENERAL	±5.0														
		ONE DECIMAL PLACE	±0.1														
TWO DECIMAL PLACE	±0.1																
ANGULAR (°)	±1.0																
DWN	H SINGH	20/01/2022															
MATERIAL																	
THICKNESS																	
		FINISH															

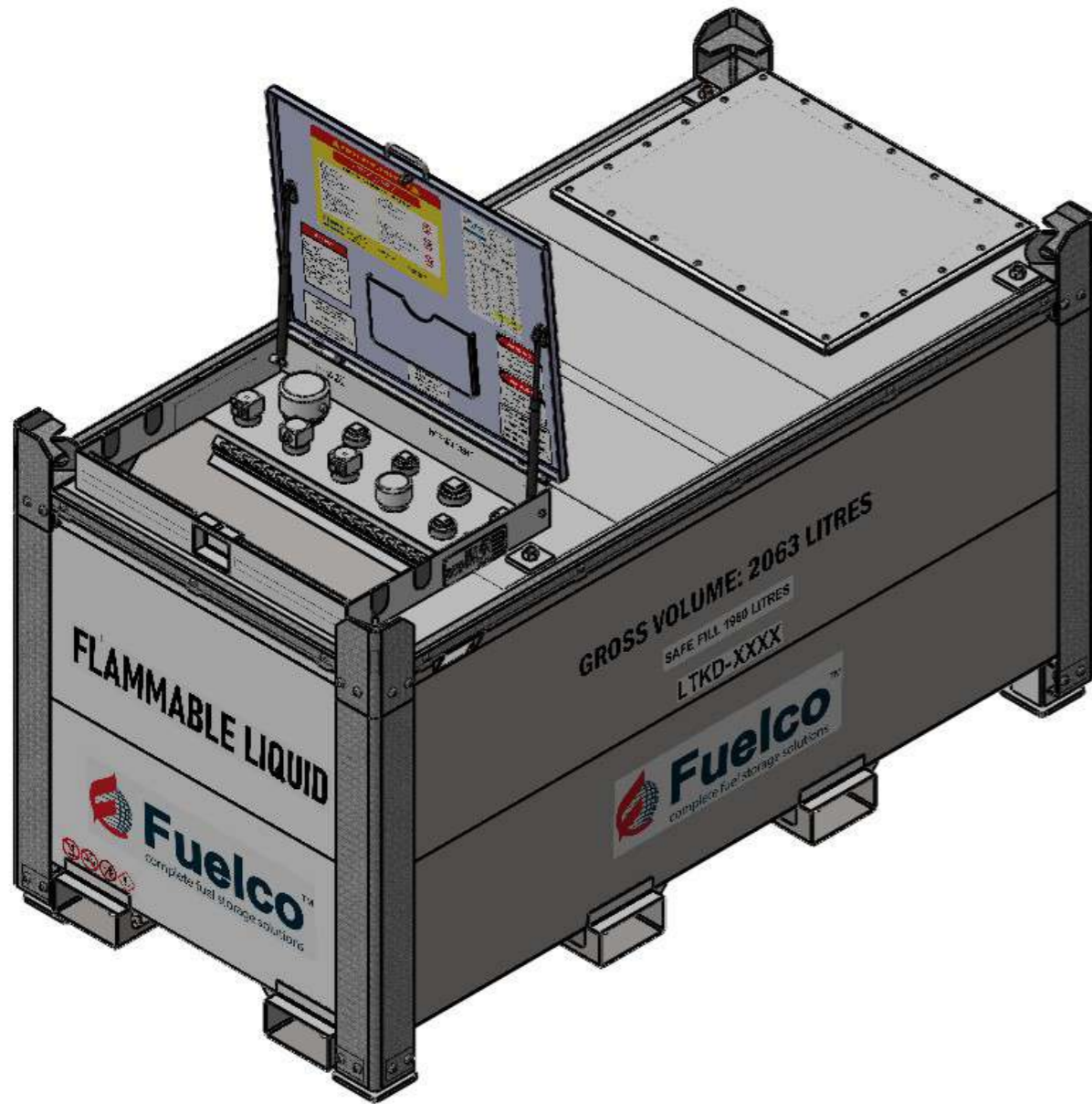

TANK WITH STANDARD HATCH COVER

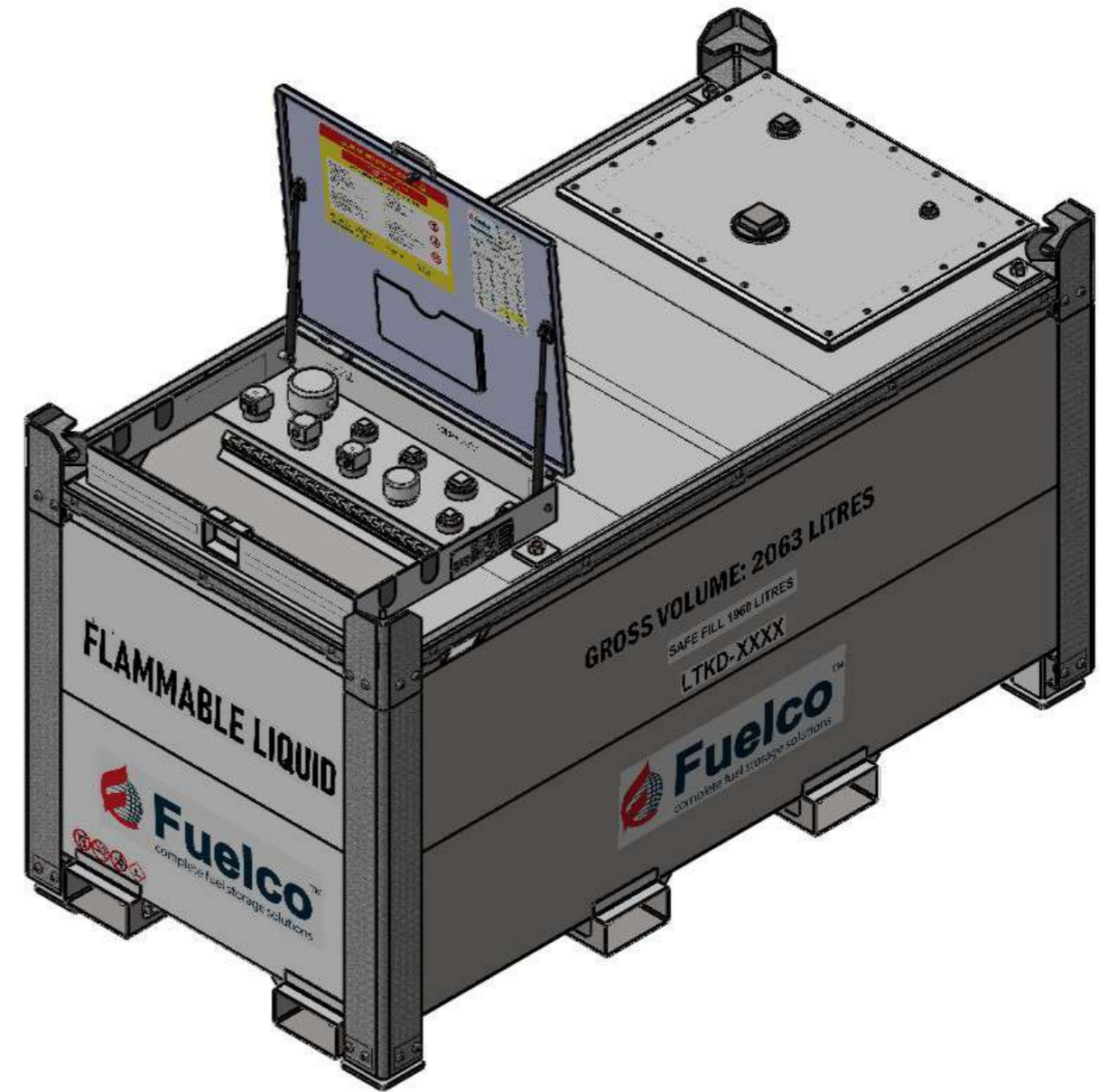

TANK WITH HATCH COVER FOR AUSTRALIA/NZ

**IF IN DOUBT ASK.
DRAWING INFORMATION TAKES PRECEDENCE OVER PARTS LIST**

Part of the Eredyne Group

COPYRIGHT. This drawing and the information herein is the property of Fuelco PTY LTD and must not be reproduced, transmitted or disclosed to other parties without written permission from the owners

GENERAL NOTES
DO NOT SCALE
UNLESS STATED OTHERWISE:-
ALL DIMENSIONS IN MILLIMETERS
ALL THREADS ARE METRIC COARSE
DEBURR & REMOVE ALL SHARP EDGES
TOLERANCES:

TYPE	TOLERANCE
GENERAL	±5.0
ONE DECIMAL PLACE	±0.1
TWO DECIMAL PLACE	±0.1
ANGULAR (°)	±1.0

SCALE	NTS
DWN	H SINGH 20/01/2022
MATERIAL	
THICKNESS	
FINISH	

TITLE	LTKD2 ASSEMBLY NOZZLE SCHEDULE
DRAWING NUMBER	LTKD2-GA
SHEET 3 OF 3	
REV	7



A3