

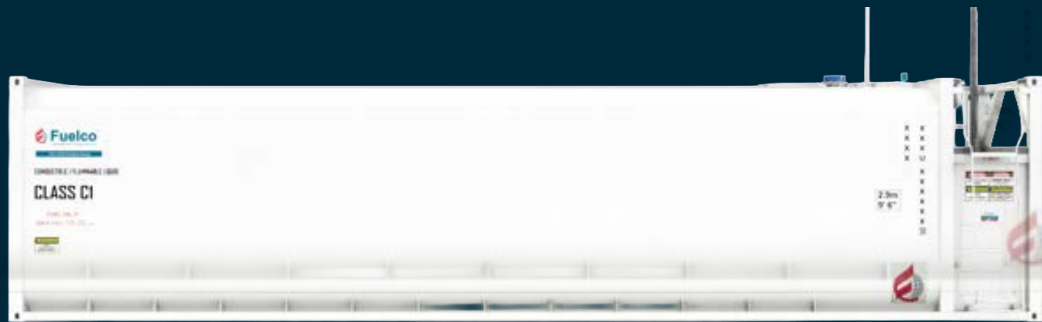

FuelcoTM
complete fuel storage solutions



SPEC SHEET

**Kommander Tanks
LTKO 68**

Kommander – LTKO 68

Features:

- Self bunded double wall design with
- Fluid level dipstick for tank and interstitial space
- Vent pipe for tank and interstitial space
- Suction foot valve, overfill protection and electronic overfill alarm
- Corner container lock castings for ease of transport
- Access manway
- Warranty - 5 years structural, 1 year on valves (conditions apply)

Pump bay model standard with:

- Bunded pump bay with lockable weatherproof doors (roller shutter door optional)
- Galvanised access ladder and platform; with ladder fitted to either side of the platform (ex-factory)
- Galvanised kick plate and middle rail provided for additional



Specification	Details
Tank Mode	LTKO 68
Gross Fill	69,288 litres
SFL	65,750 litres
Length	12,192 mm
Width	2438 mm
Height	2896 mm
Empty Weight	12,158 kg
Vent Pipe	Standard
Fluid Level Dipstick	Standard
Compliance	AS1940, AS1692, AS1657, UL142, ULCS601, CSC

Disclaimer: Information and photographs shown are for marketing purposes only. Actual product may vary to images shown due to continual improvement processes, design changes and optional extras.

Contact details:

+61 (03) 9775 1366
 sales@fuelco.com.au
 fuelco.com.au

Request a Quote Today

Fuelco holds stock of these tanks in ALL states across Australia. For details on availability and pricing, please contact your local state manager.



TANK DATA	
DESIGNED TO:	AS1692, AS1940, UL142, ULC S601, CSC
BUILT TO:	AS1692, UL142, ULC S601, CSC
TESTED TO:	UL142, CSC
OUTER / INNER WALL THICKNESS:	5mm / 5mm
GROSS VOLUME:	69 288L; 18 304 US gal
SAFE FILL LEVEL (VOLUME):	65 750L; 17 369 US gal (95%)
LEAK TEST PRESSURE:	21-35 kPa; 3-5 psi
PAINT SPECIFICATION:	HEMPEL PAINT 1st: HEMPADUR ZINC 17360: 50 µm 2nd: HEMPADUR FAST DRY 15560: 100 µm 3rd: HEMPATANE HS 55610: 50 µm COLOUR: HEMPEL 10000 - GLOSSY WHITE
TOTAL MASS (EMPTY):	12 158 kg

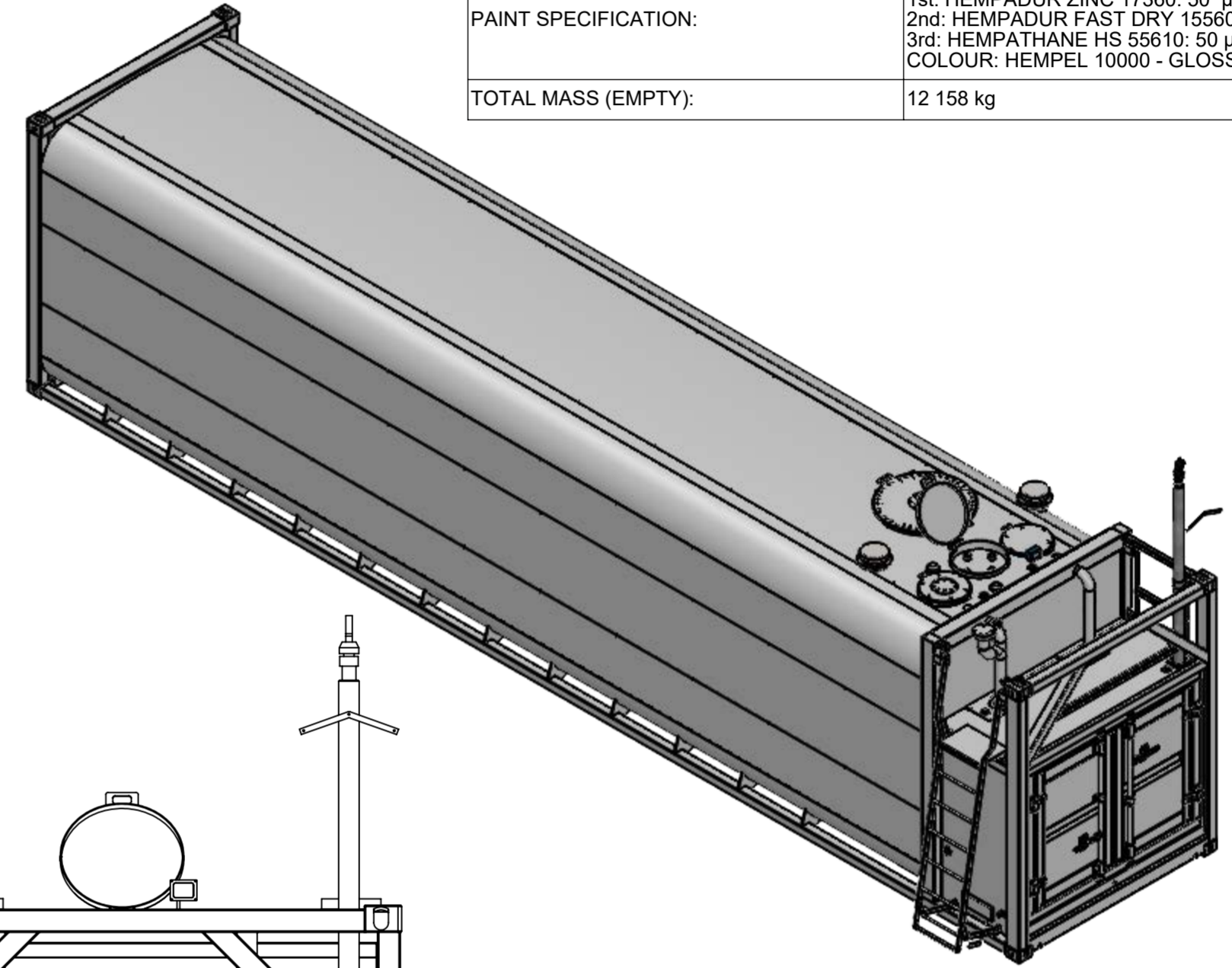
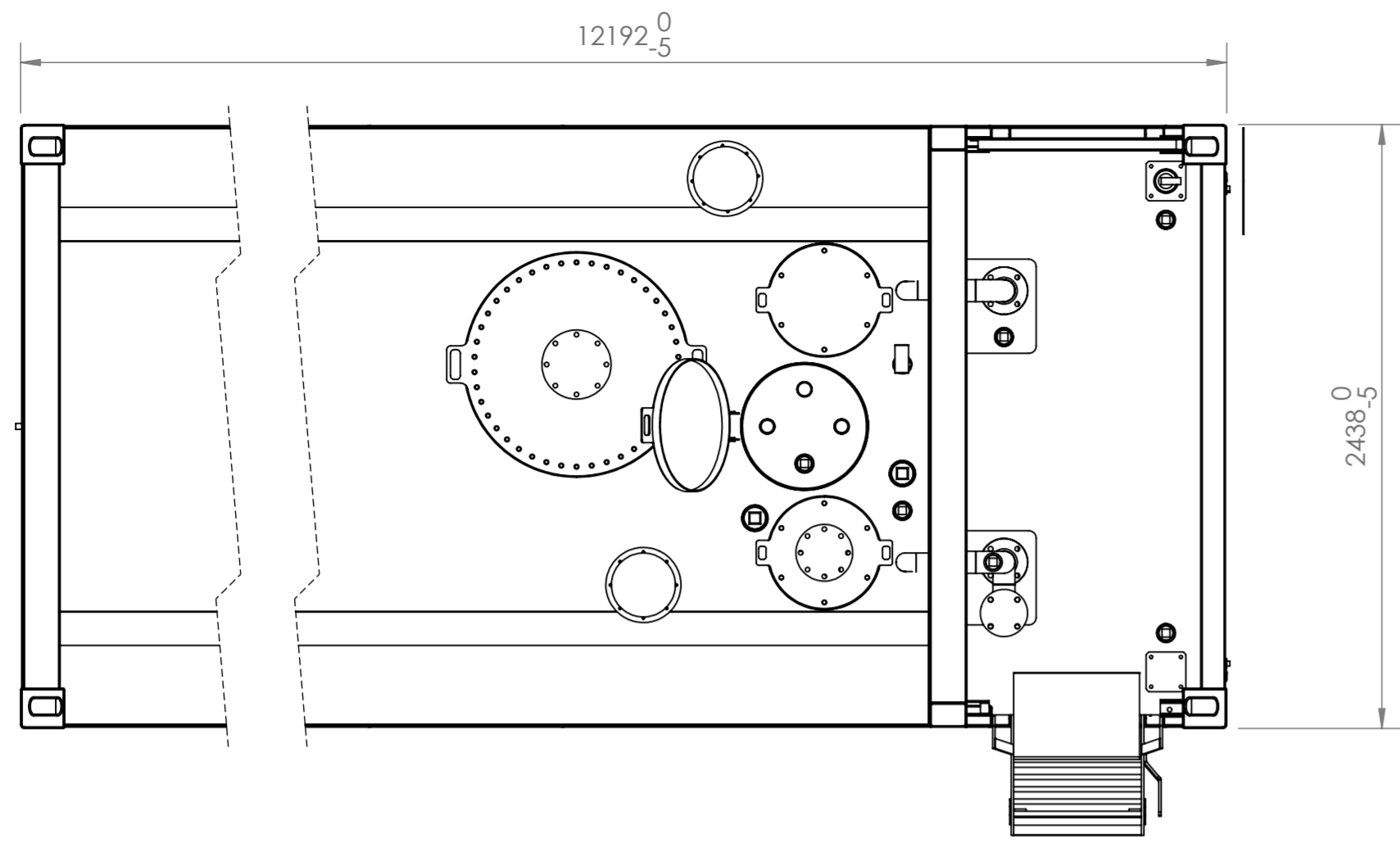

SINGLE HOSE MAST SUPPLIED AS STANDARD, CAN BE FITTED ON EITHER SIDE OF PUMPBAY

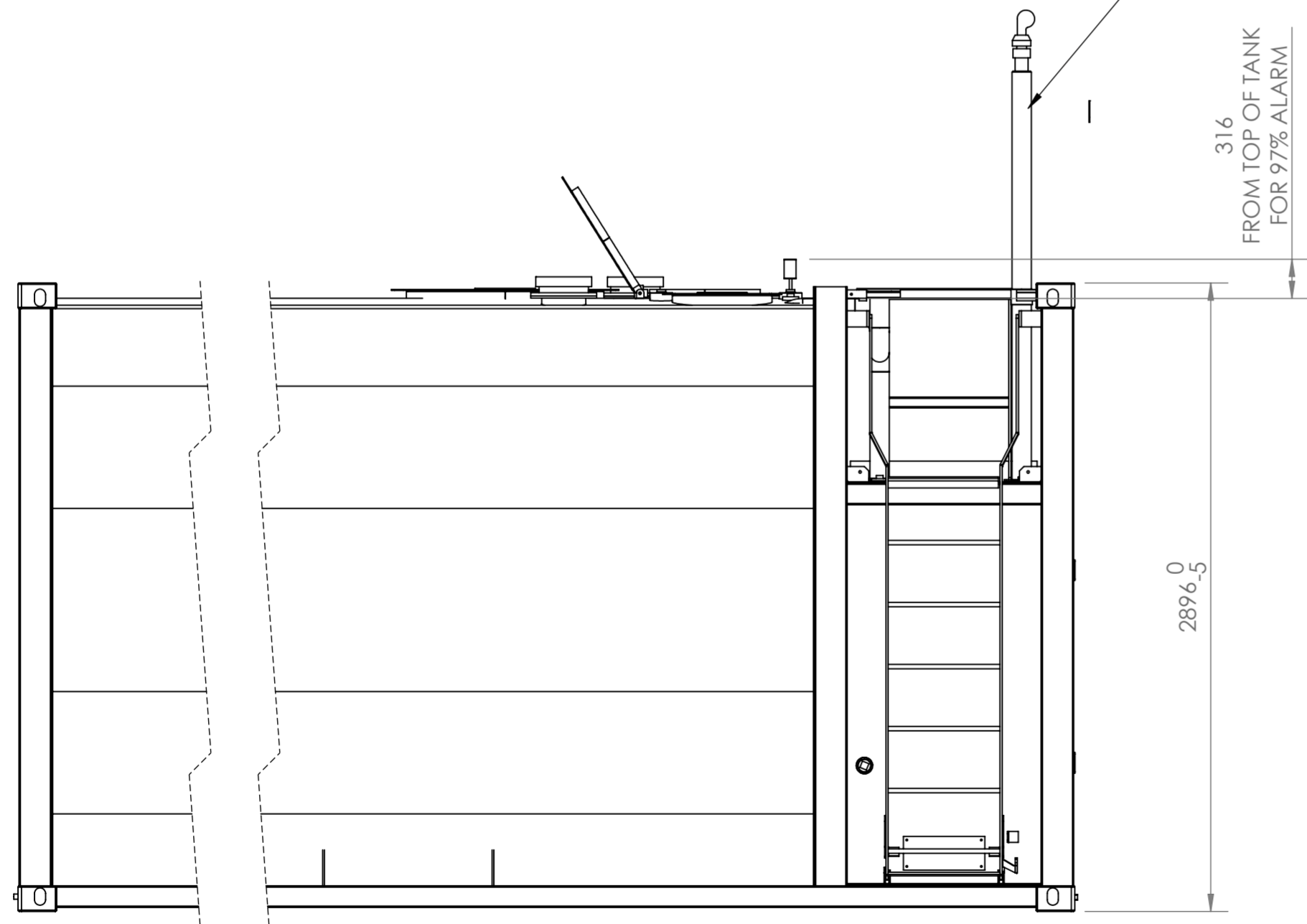

1 x AS1657 ACCESS LADDER SUPPLIED, CAN BE FITTED TO BOTH SIDES OF TANK HAND RAIL INSERT PROVIDED FOR OPPOSITE SIDE

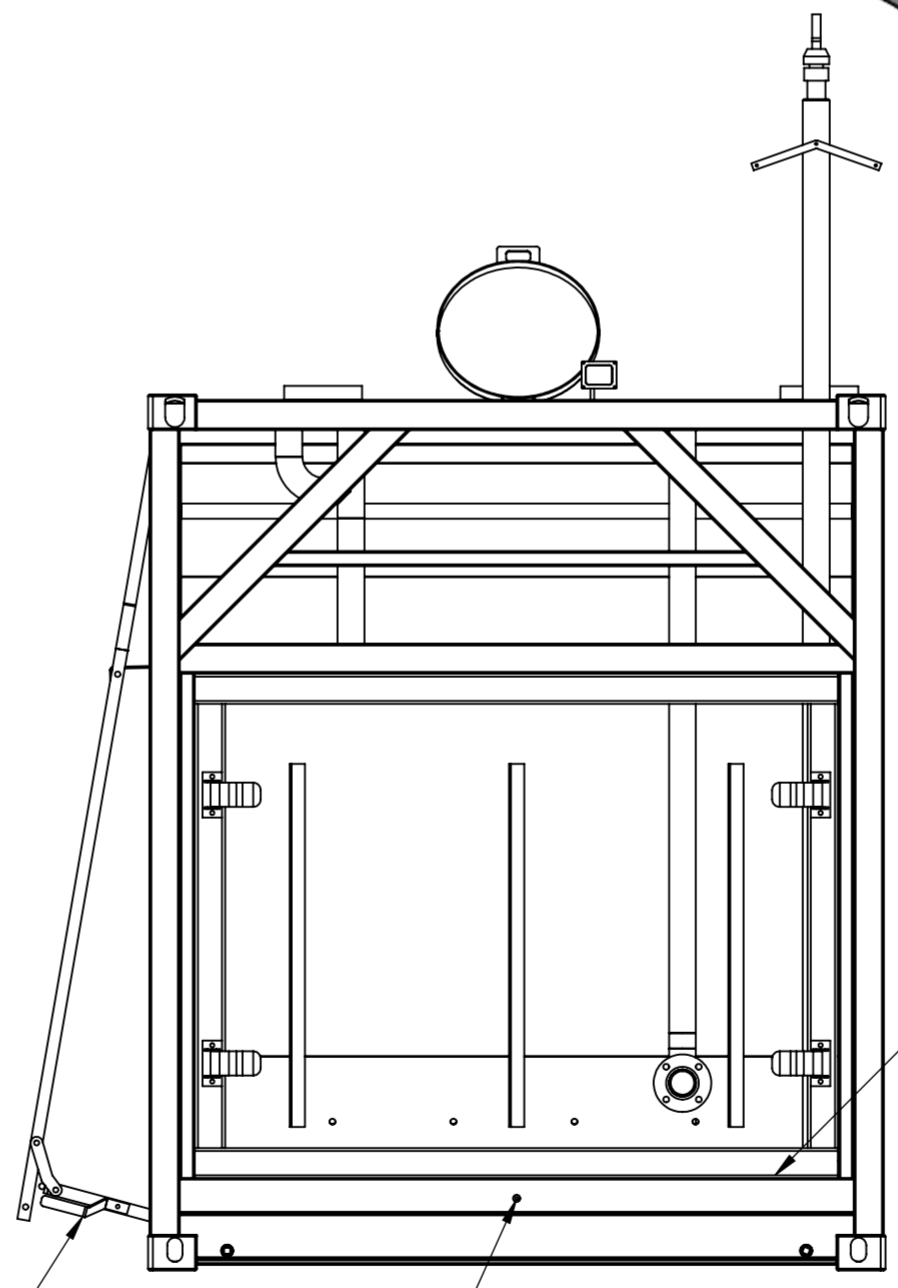

LOCKABLE DOORS - HIDDEN FOR CLARITY

IF IN DOUBT ASK. DRAWING INFORMATION TAKES PRECEDENCE OVER PARTS LIST

 complete fuel storage solutions	GENERAL NOTES DO NOT SCALE UNLESS STATED OTHERWISE- ALL DIMENSIONS IN MILLIMETERS ALL THREADS ARE METRIC COARSE DEBURR & REMOVE ALL SHARP EDGES TOLERANCES: TYPE TOLERANCE GENERAL ±5.0 ONE DECIMAL PLACE ±0.1 TWO DECIMAL PLACE ±0.1 ANGULAR (°) ±1.0	SCALE	NTS	TITLE
		DWN	LIB	12/5/2022
Part of the Eredyne Group		CLIENT		DRAWING NUMBER
COPYRIGHT: This drawing and the information herein is the property of Fuelco PTY LTD and must not be reproduced, transmitted or disclosed to other parties without written permission from the owners.		END USER		LTKO68-GA-00

A	ISSUED FOR INFORMATION	12/05/2022	LIB	HS
REV.	DESCRIPTION	DATE	DWN	APP

REVISIONS

E:\Eredyne Group Dropbox\Lionel

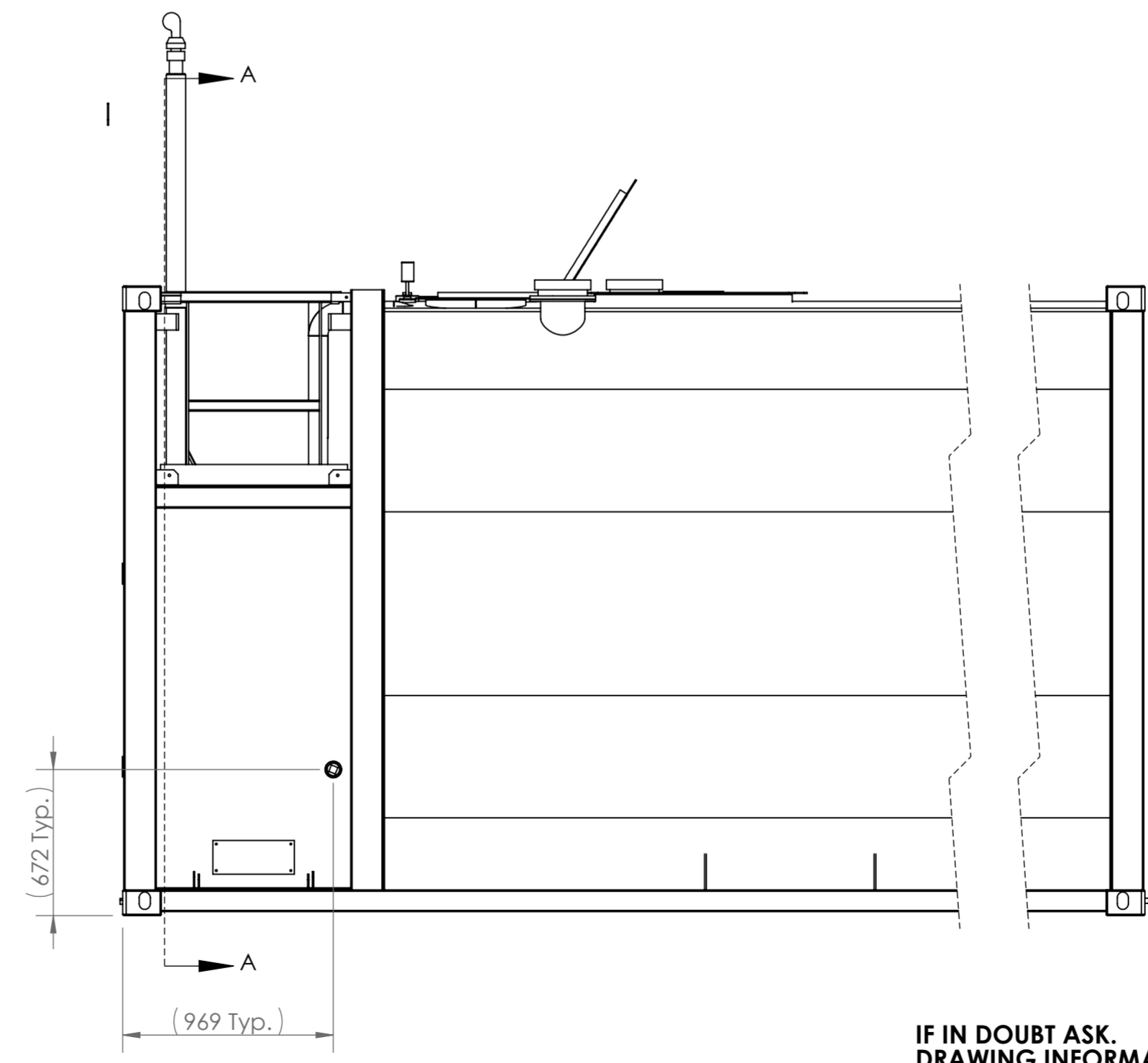
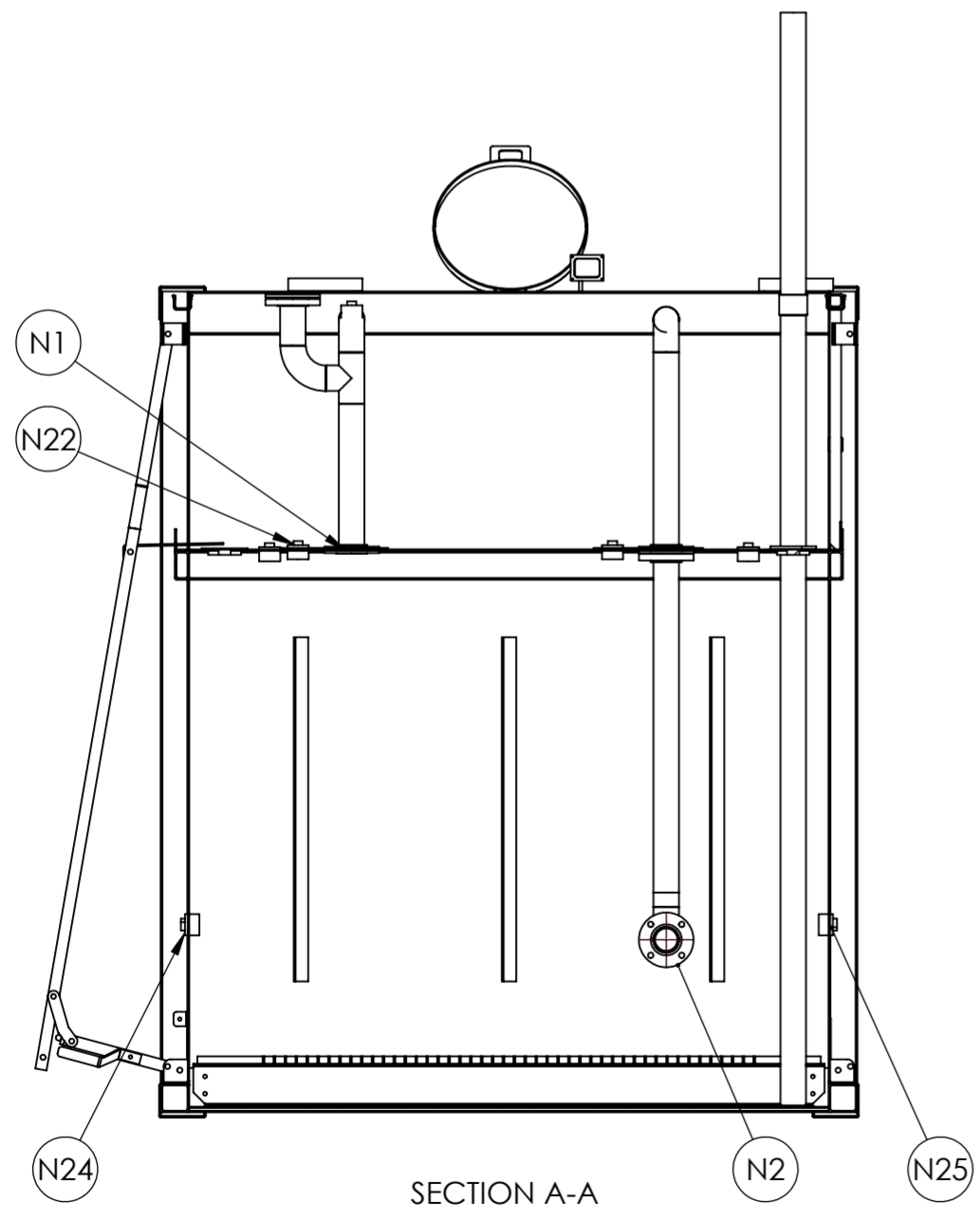
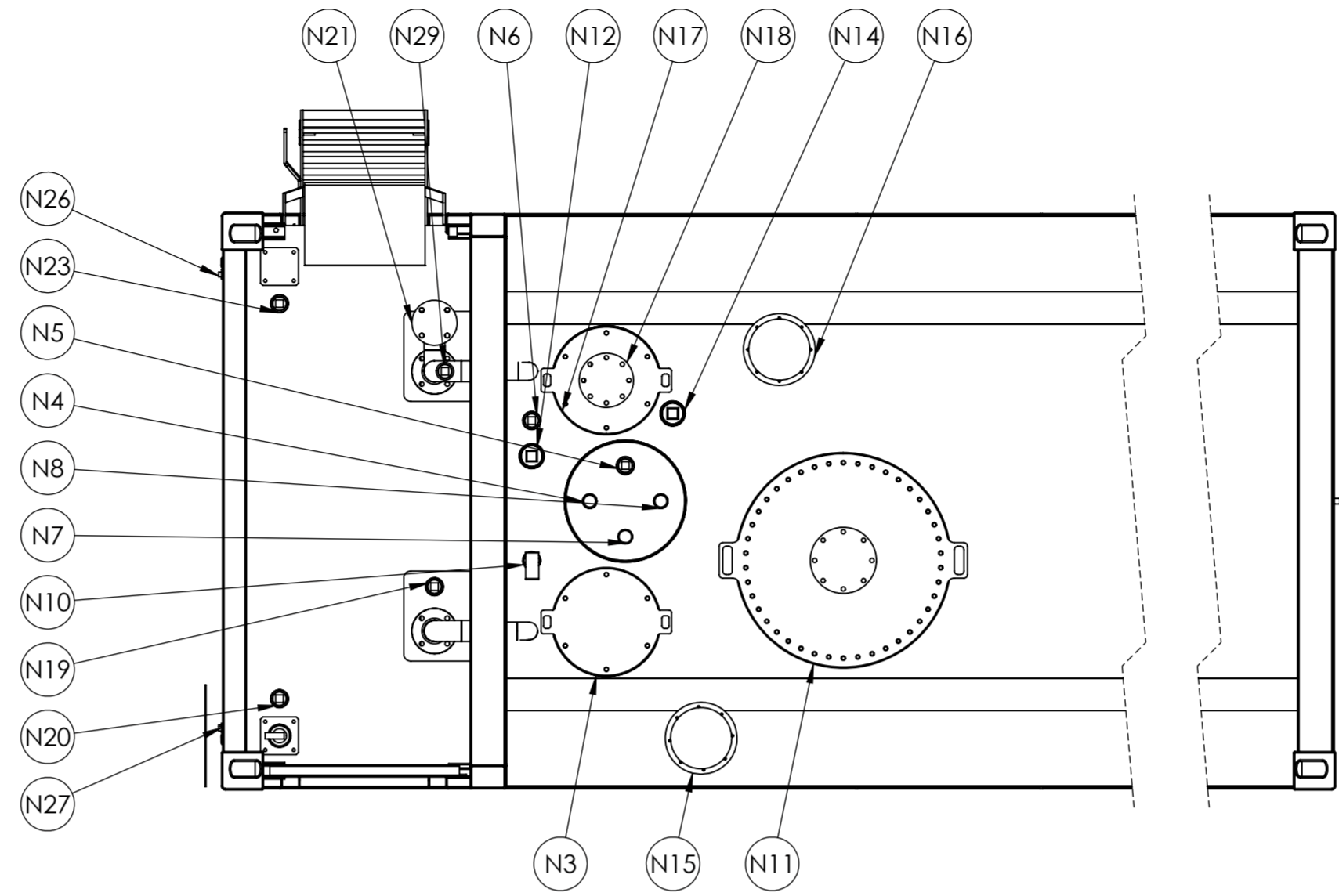

NOZZLE NO.	SIZE	CONNECTION TYPE	DESCRIPTION
N1	DN80	ASME CLASS 150 FLANGE	SUCTION C/W DN80 PIPE TO FLOOR & FOOT VALVE
N2	DN80	ASME CLASS 150 FLANGE	FILL PIPE C/W DN80 PIPE TO FLOOR, OVERFILL PROTECTION VALVE, CHECK VALVE, BALL VALVE AND CAMLOCK
N3	350	INSPECTION HATCH	INSPECTION HATCH WITH ACCESS TO OVER FILL PROTECTION VALVE
N4	DN50	BSP-F x 50 LONG	SPARE
N5	DN50	BSP-F x 50 LONG	SPARE
N6	DN50	BSP-F x 50 LONG	SPARE / GAUGE
N7	DN50	BSP-M x 35 LONG	PRIMARY TANK DIP C/W DN50 PIPE TO FLOOR & LOCKABLE DIP CAP
N8	DN50	BSP-M x 35 LONG	INTERSTITIAL SPACE DIP C/W DN50 PIPE THROUGH INTERNAL FLOOR & LOCKABLE DIP CAP
N9			NOT USED
N10	DN50	BSP-F x 50 LONG	C/W OVERFILL WARNING ALARM
N11	600	MANWAY	MANWAY C/W LADDER ACCESS TO TANK INTERNAL
N12	DN80	BSP-F x 75 LONG	SPARE / GAUGE
N13			NOT USED
N14	DN80	BSP-F x 35 LONG	FREE VENT C/W RISER & VENT CAP SUPPLIED LOOSE
N15	DN200	ASME CLASS 150 FLANGE	INTERSTITIAL SPACE EMERGENCY VENT C/W DN200 PIPE CONNECTED THROUGH INTERNAL SKIN
N16	DN200	ASME CLASS 150 FLANGE	PRIMARY EMERGENCY VENT
N17	350	INSPECTION HATCH	INSPECTION HATCH WITH ACCESS TO FOOT VALVE
N18	DN150	ASME CLASS 150 FLANGE	SPARE / SUBMERSIBLE PUMP
N19	DN50	BSP-F x 50 LONG	SPARE (INTO PUMP BAY)
N20	DN50	BSP-F x 50 LONG	HIGH MAST DISPENSING
N21	DN80	ASME CLASS 150 FLANGE	SUCTION PRIMING PORT / SUBMERSIBLE PUMP CONNECTION
N22	DN50	BSP-F x 50 LONG	SPARE (INTO PUMP BAY) / SUB PUMP ELECTRICALS
N23	DN50	BSP-F x 50 LONG	HIGH MAST DISPENSING
N24	DN50	BSP-F x 50 LONG	SPARE (INTO PUMP BAY) / EXTERNAL ELECTRICALS
N25	DN50	BSP-F x 50 LONG	SPARE (INTO PUMP BAY) / EXTERNAL ELECTRICALS
N26	DN25	BSP-F x 45 LONG	PUMP BUND DRAIN
N27	DN25	BSP-F x 45 LONG	PUMP BUND DRAIN
N28			NOT USED
N29	DN50	BSP-F x 50 LONG	PRIME POINT

BSP-F: BSP FEMALE THREAD
BSP-M: BSP MALE THREAD

IF IN DOUBT ASK. DRAWING INFORMATION TAKES PRECEDENCE OVER PARTS LIST

COPYRIGHT: This drawing and the information herein is the property of Fuelco PTY LTD and must not be reproduced, transmitted or disclosed to other parties without written permission from the owners.

GENERAL NOTES
DO NOT SCALE
UNLESS STATED OTHERWISE:-
ALL DIMENSIONS IN MILLIMETERS
ALL THREADS ARE METRIC COARSE
DEBURR & REMOVE ALL SHARP EDGES
TOLERANCES:

TYPE	TOLERANCE
GENERAL	±5.0
ONE DECIMAL PLACE	±0.1
TWO DECIMAL PLACE	±0.1
ANGULAR (°)	±1.0

SCALE	NTS	TITLE
DWN	LIB	12/5/2022
CUSTOMER		
END USER		

DRAWING NUMBER
LTKO68-GA-00

TITLE
LTKO68 KOMMANDER BULK TANK
GENERAL ARRANGEMENT
STANDARD CONFIGURATION
SHEET 2 OF 2

REV
A